

User Guide

Pantum PT14C2A Series
(CM2100 Series)
Color laser multifunction printer (FB model)

PANTUM

Preface

Welcome to the Pantum series products!

We heartily appreciate your using of Pantum series products!

To protect your vital interests, please carefully read the following statements.

For more information, please visit our official website (www.pantum.com).

Legal Notice

Trademark

Pantum and Pantum logos are registered trademarks of Zhuhai Pantum Electronics Co., Ltd.

Microsoft[®], Windows[®], Windows Server[®] and Windows Vista[®] are trademarks registered by Microsoft Corporation in the United States or other countries/regions.

Apple, AirPrint, Mac, and macOS are trademarks of Apple Inc., registered in the U.S. and other countries. Use of the Works with Apple badge means that an accessory has been designed to work specifically with the technology identified in the badge and has been certified by the developer to meet Apple performance standards.

The Mopria™ word mark and the Mopria™ Logo are registered and/or unregistered trademarks of Mopria Alliance, Inc. in the United States and other countries. Unauthorized use is strictly prohibited.

The Bluetooth[®] word mark and logos are registered trademarks owned by Bluetooth SIG, Inc. and any use of such marks by Zhuhai Pantum Electronics Co., Ltd. is under license. Other trademarks and trade names are those of their respective owners.

Wi-Fi Direct, Wi-Fi Protected Setup (WPS), WPA, WPA2, WPA3 and Wi-Fi Protected Access are marks of the Wi-Fi Alliance.

The ownership to the names of the software in this User Guide belongs to their respective owned companies in accordance with corresponding license agreement, and they are referred for instructions only.

All other product and brand names herein may be the registered trademarks, trademarks or service marks of their respective owners, and they are referred for instructions only.

Copyright

The copyright of this User Guide is owned by Zhuhai Pantum Electronics Co., Ltd.

It is prohibited to copy, translate, modify and transmit this User Guide by any means or forms without the prior written consent of Zhuhai Pantum Electronics Co., Ltd.

Version:V1.2

Disclaimer

For a better user experience, Zhuhai Pantum Electronics Co., Ltd. reserves the right to make changes to the User Guide. The information contained herein is subject to change without notice. Users are responsible for any damages arising from failing to follow this User Guide. Meanwhile, except the express warranty made in the product maintenance manual or service commitment, Zhuhai Pantum Electronics Co., Ltd. does not make any express or implied warranty or guarantee to this User Guide (including composing or words).

Using this product to copy, print, scan certain documents or images or make other forms of operations may be prohibited by the local laws. If you are uncertain about the legality of using this product for certain documents or images, you should consult your legal advisor in advance.

Safety Precautions

Disconnect the power supply

The product should be placed close to or easily accessible to power sockets, so as to allow easy disconnection of power supply!

Laser Safety

The laser radiation is harmful to the human body. Since laser components are completely sealed in the printer, laser radiation will not leak. To avoid laser radiation, please do not randomly disassemble the printer!

Caution – Use of controls or adjustments or performance of procedures other than those specified herein may result in hazardous radiation exposure.

The printer follows the provisions of Class 1 laser products under CFR standard.



The printer has a Class 3B laser diode, which has no laser radiation leakage among laser components.

The laser components shall comply with the requirements of: U.S. Code of Federal Regulations, 21 CFR 1040, IEC 60825-1

The following label is attached to the laser components inside the printer:











or

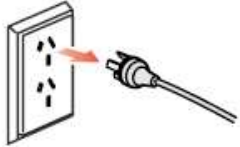

Safety Warning

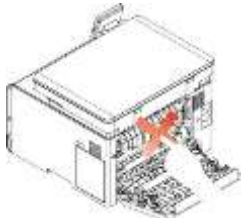
Please note the following safety warnings before using the printer:

 Warning	
 There is a high-voltage electrode inside the printer. Before cleaning the printer, make sure the power is turned off!	
 Plugging and unplugging the power cord plug with a wet hand may result in an electric shock.	
 The fuser unit is hot during and after printing. Touching the fuser unit (the shaded area as shown) may cause burns!	
 The fuser unit bears a high temperature warning label. Please do not remove or damage this label.	

Safety Information

Conventions

CAUTION: A caution indicates a potentially hazardous situation that could injure you.

Note: A note indicates the information that could help you or something that could damage the product hardware or software.

Different types of caution statements include:



CAUTION - POTENTIAL INJURY: Indicates a risk of injury.



CAUTION - SHOCK HAZARD: Indicates a risk of electrical shock.



CAUTION - HOT SURFACE: Indicates a risk of burn if touched.



CAUTION - TIPPING HAZARD: Indicates a crush hazard.



CAUTION - PINCH HAZARD: Indicates a risk of being caught between moving parts.



CAUTION - ROTATING FAN BLADES: Indicates a risk of being lacerated by moving fan blades.

Disclaimer



CAUTION - POTENTIAL INJURY: To avoid the risk of fire or electrical shock, connect the power cord to an appropriately rated and properly grounded electrical outlet that is near the product and easily accessible.



CAUTION - POTENTIAL INJURY: To avoid the risk of fire or electrical shock, use only the power cord provided with this product or the manufacturer's authorized replacement.



CAUTION - POTENTIAL INJURY: Do not use this product with extension cords, multioutlet power strips, multioutlet extenders, or UPS devices. The power capacity of these types of accessories can be easily overloaded by a laser printer and may result in a risk of fire, property damage, or poor printer performance.



CAUTION - POTENTIAL INJURY: Do not use this product with an inline surge protector. The use of a surge protection device may result in a risk of fire, property damage, or poor printer performance.



CAUTION - SHOCK HAZARD: To avoid the risk of electrical shock, do not place or use this product near water or wet locations.



CAUTION - SHOCK HAZARD: To avoid the risk of electrical shock, do not set up this product or make any electrical or cabling connections during a lightning storm.



CAUTION - POTENTIAL INJURY: Do not cut, twist, bind, crush, or place heavy objects on the power cord. Do not subject the power cord to abrasion or stress. Do not pinch the power cord between objects such as furniture and walls. If any of these things happen, it could result in a risk

of fire or electrical shock. Inspect the power cord regularly for signs of such problems. Remove the power cord from the electrical outlet before inspecting it.



CAUTION - SHOCK HAZARD: To avoid the risk of electrical shock, make sure that all external connections (such as Ethernet) are properly installed in their marked plug-in ports.



CAUTION - SHOCK HAZARD: To avoid the risk of electrical shock, if you are accessing the controller board or installing optional hardware or memory devices after setting up the printer, turn the printer off, and unplug the power cord from the electrical outlet before continuing. If you have any other devices attached to the printer, turn them off as well, and unplug any cables going into the printer.



CAUTION - SHOCK HAZARD: To avoid the risk of electrical shock when cleaning the exterior of the printer, unplug the power cord from the electrical outlet and disconnect all cables from the printer before proceeding.



CAUTION - POTENTIAL INJURY: If the printer weighs more than 18 kg, then it requires two or more trained personnel to lift it safely.



CAUTION - POTENTIAL INJURY: When moving the printer, follow these guidelines to avoid personal injury or printer damage:

- Make sure that all covers and trays are closed.
- Turn off the printer, and then unplug the power cord from the electrical outlet.
- Disconnect all cords and cables from the printer.
- If the printer has casters on its base, then carefully move it to the new location. Use caution when passing over thresholds and breaks in flooring.
- Always use the handholds on the printer to lift it.
- Any cart used to move the printer must have a surface able to support the full footprint of the printer.
- Keep the printer upright.
- Avoid violent vibrations when moving.
- Make sure that your fingers are not under the printer when you set it down.
- Make sure that there is adequate clearance around the printer.



CAUTION - HOT SURFACE: The inside of the printer might be hot. To reduce the risk of injury by a hot component, allow the surface to cool before touching it.



CAUTION - HOT SURFACE: Some parts of the printer are still in high temperature within a short time after use. To prevent burns, please don't directly touch places labeled with high temperature warning in contact with internal components after opening the printer's front or rear cover.



CAUTION - PINCH HAZARD: To avoid the risk of a pinch injury, use caution in areas marked with this label. Pinch injuries may occur around moving parts, such as gears, covers, trays, and covers.



CAUTION - ROTATING FAN BLADES: To avoid the risk of laceration from moving fan blades, turn off the printer and unplug the power cord from the electrical outlet before accessing areas marked with this symbol.



CAUTION - POTENTIAL INJURY: This product uses lasers. Use of controls or adjustments or performance of procedures other than those specified in the User's Guide may result in hazardous radiation exposure.

This product is designed, tested, and approved to meet strict global safety standards with the use of specific manufacturer's components. The safety features of some parts may not always be obvious. The manufacturer is not responsible for any adverse consequences caused by using parts of other manufacturers.

For services or repairs other than those described in the user document, please contact the Customer Service Center.

This product uses a printing process that heats the print media, and the heat may cause the media to release emissions. Please read and understand the section in your operating instructions that discusses the guidelines for selecting print media properly to avoid the possibility of harmful emissions.

This product may produce a small amount of ozone during normal operation, and may be equipped with a filter designed to limit ozone concentrations to levels well below the recommended exposure limits. To avoid high ozone concentration levels during extensive usage, install this product in a well-ventilated area and replace the ozone and exhaust filters if instructed to do so in the product maintenance instructions. If there are no references to filters in the product maintenance instructions, then it is not required to replace the filter for this product.

Please keep these safety instructions.

Precautions

Precautions before Using the Printer:

1. Read and understand all instructions;
2. Familiarize yourself with the basic principles associated with operating electrical appliances;
3. Comply with all warnings and instructions marked on the equipment or specified in the manual supplied with the equipment;
4. If the operating instructions conflict with the safety information, please refer back to the safety information, as you may have misunderstood the operating instructions. If you cannot resolve the conflicts, please call the Customer Service Hotline or contact a service representative for help;
5. Before cleaning the equipment, remove the power cord from the AC power supply outlet. Do not use liquid or aerosol cleaners;
6. Please make sure that the equipment is put on a stable desktop surface to avoid serious damage caused by the falling of the equipment;
7. Do not put the equipment near a radiator, an air conditioner, or a ventilation pipe;
8. Do not put any articles on the power cord. Do not put the equipment at the place where its power cord could be stepped on by people;
9. Outlets and extension cords must not be overloaded. This may reduce performance and could result in fire or electric shock;
10. Do not allow pets to chew on the AC power cord or the computer interface cable;
11. Do not allow sharp objects piercing equipment slot, so as to avoid contact with the high-voltage device, which otherwise may result in fire or electric shock. Take care not to spill liquids onto the equipment;
12. Do not disassemble the equipment so as to avoid the risk of electric shock. Necessary repairs may only be carried out by professional maintenance personnel. Opening or removing the cover could result in an electric shock or other potential hazards. Incorrect disassembly and assembly could also result in an electric shock during future use;
13. If any one of the following occurs, disconnect the equipment from the computer and pull out the power cord from the AC wall socket and contact a qualified member of the service personnel for maintenance:
 - Liquid has been spilled into the equipment.
 - The equipment has been exposed to rain or water.
 - The equipment falls, or the cover is damaged.
 - Significant changes in the equipment's performance.
14. Only adjust the control mentioned in the instructions. Incorrect adjustment of other controls may result in damage and mean that professional maintenance personnel need to spend more time fixing it;
15. Do not use the equipment in a thunderstorm so as to avoid the risk of an electric shock. If possible, pull out the AC power cord during a thunderstorm;
16. If you continuously print multiple pages, the surface of the tray will become very hot. Take care not to touch this surface, and keep children away from this surface;
17. The signal wire of the device connected with the printer can not be connected to the outdoors;

18. Please ensure timely ventilation in case of a prolonged use or printing huge amounts of documents in a poorly ventilated room;
19. In standby status, the product will automatically enter into the power saving (sleep) mode if it does not receive any job order for a while (such as 1 minute); and it can realize zero power consumption only if it has not been connected with any external input power supply;
20. As the Class 1 equipment, the product must be connected to the power supply outlet with protective grounding line when using;
21. This product should be placed according to the shipping marks on the product package box during delivery;
22. This product is a kind of low-voltage equipment. When using this product below the specified voltage range, please refer to the product precautions or call Pantum Aftersales Service Centre, if the toner comes off the printed contents, or the equipment starts slowly;
23. This product is sold as a complete machine. The consumers can go to Pantum Aftersales Service Centre to purchase parts they need. If the product sold is inconsistent with the package list, please go to the specified Aftersales Service Centre to solve the problem;
24. Install this product in a place with the temperature between 10°C and 35°C and the relative humidity between 20% and 80%;
25. For security and other reasons the printer may switch to intermittent printing after a certain amount of continuous printing;
26. Warning: changes or modifications not expressly approved by the party responsible for compliance could void the user's authority to operate the equipment.
27. The power consumption of the product with wireless function is 8.00W / without wireless function is 2.00W in networked standby if all wired network ports are connected and all wireless network ports are activated.
28. RF Radiation Exposure Statement Caution: To maintain compliance with the RF exposure guidelines, place the product at least 20cm from nearby persons.
29. To avoid the danger of fire or electric shock, please only use the power cord provided with this product or authorized replacements approved by the manufacturer.
30. The power cord provided with this product is intended for this product only. Do not use it with other devices as it may cause fire, electric shock, or other injuries.
31. Do not use flammable sprays or combustible solvents near or inside the machine. Additionally, do not place them near or inside the machine as it may cause fire or electric shock.
32. Please keep this User Guide properly.

Legal Information



This symbol indicates that, at the end of your product's life, it must not be discarded as domestic waste. Instead, you should dispose of your used equipment at a designated collection point for the recycling of waste electrical and electronic equipment. Ref: EU Directive 2002/96/EC on Waste Electrical and Electronic Equipment (WEEE). Please contact your distributor / supplier for further information.



This symbol indicates that the product is applicable to indoor use instead of outdoor use.



European Community (EC) directives conformity

This product complies with the protection requirements of EC directives 2014/30/EU and 2014/35/EU on the approximation and harmonization of the laws of the Member States relating to electromagnetic compatibility and safety of electrical equipment designed for use within certain voltage limits.

Radio Equipment Directive 2014/53/EU is only applicable to models with Wireless function.

The manufacturer of this product is: Zhuhai Pantum Electronics Co., Ltd., Building 02,06 and 08, No.888 Shengping Avenue, Pingsha Town, Zhuhai City, Guangdong Province, 519000 PR China

A declaration of conformity to the requirements of the Directives is available upon request from the Authorized Representative.

This product satisfies the Class B limits of EN 55032 / EN 55035 and safety requirements of EN 62368-1.

Table of Contents

01 Before Using the Printer	1
Product View.....	1
Control Panel	3
Function of power indicator	4
02 Paper and Print Media	5
Paper Specification	5
Special Paper.....	6
Einlegen von Papier.....	7
Load in the standard feed tray.....	7
Install the multipurpose feed tray.....	9
Paper and Manuscript Use Process.....	10
03 Driver installation and uninstallation.....	11
Driver Setup.....	11
One-click Installation (For Windows and macOS).....	11
Uninstall Driver.....	12
Method to uninstall driver under Windows	12
04 Wired network setup (applicable to wired network models)	13
Set IP Address	13
Automatic Setting	13
Manual Setting	13
05 Wireless network setup (applicable to Wi-Fi models).....	14
Basic structure mode.....	14
Wireless network setup tools.....	15
Preliminary preparations	15
Setup methods of wireless network setup tools.....	15
How to disable the Wi-Fi network connected.....	15
06 Web server.....	16
Visit the embedded Web server.....	16
07 Print.....	17
Print Function.....	17
Duplex	18
Print without margins	错误!未定义书签。
Red Auto Enhancement function.....	20
Set transfer print parameters.....	22
08 Copying.....	24

Copying function	24
Common copying setting.....	24
Multipage.....	25
Duplex copy.....	26
ID copy settings	28
Receipt setting.....	28
09 Scan	29
Pull Scan	29
Windows system scan.....	29
macOS System Scan	30
Push Scan	31
Scan to PC.....	31
Scan to E-mail	31
Scan to FTP	32
10 Routine Maintenance.....	33
Cleaning the Printer	33
Please use mild detergents.....	33
Replacing parts and consumables.....	35
Replacing the toner cartridge.....	36
Replacing the waste toner bottle.....	40
Replace the tray	41
Move the printer.....	42
Move the printer to another location.....	42
Transporting the printer	42
11 Troubleshooting.....	43
Avoiding jams	43
Correct loading of paper.....	43
Use recommended paper.....	44
Locate jammed paper	45
Cleaning Jammed Paper.....	46
Paper jam in the automatic tray.....	46
The paper is jammed in the manual feed tray	48
Paper jam in the manual tray	50
Paper jam in the rear cover	51
Software Failure.....	54
Error Message.....	55
Common Troubleshooting.....	56

Common Problems.....	56
Image Defects.....	58
12 Product Specifications	63
Overview of the Specifications	63
Print Specifications	65
Copy Specifications.....	65
Scan Specifications.....	65

01 Before Using the Printer

Product View

Side view

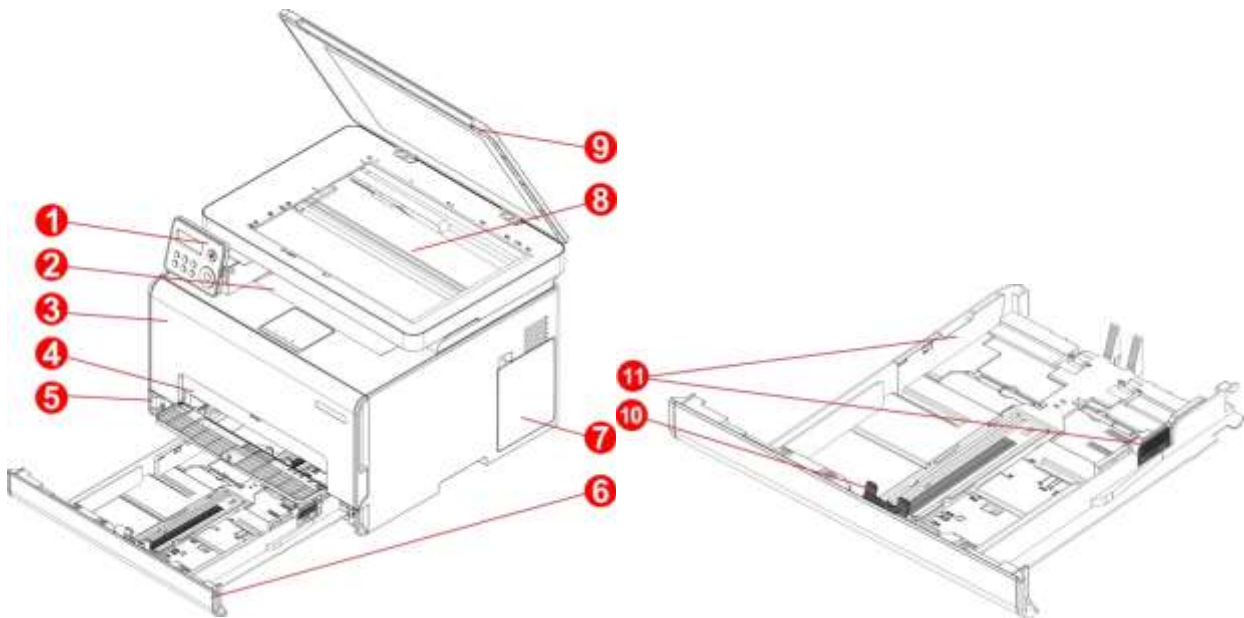

1	Control Panel	Indicate printer status to conduct set operation.
2	Standard exit	For storing the printed paper.
3	Front Cover	To open the front cover to take out the laser toner cartridge.
4	Multipurpose feed tray	For placing media to be printed in multi-purpose tray.
5	Width guide plate of multipurpose feed tray	Slide paper deflector to adapt to paper width.
6	Standard feed tray	For placing the media for printing from the standard feed tray.
7	Waste toner bottle	Store the waste toner produced in printing.
8	Glass Platen	To put the original of tablet PC for scan.
9	Cover of scanner	Open the cover of scanner to place the scanned originals on its glass plate.
10	Length guide plate of standard feed tray	Slide paper length deflector to adapt to paper length.
11	Width guide plate of standard feed tray	Slide paper deflector to adapt to paper width.

Note: • Printer appearance may vary depending on the printer model and configuration; the schematic diagram is for reference only.

Rear View

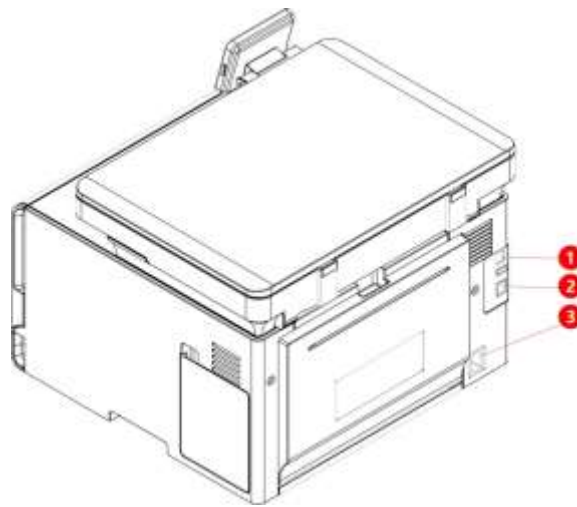

1	USB Interface	For connecting product to computer with USB cable.
2	Network Interface(applicable to models supporting network function)	For connecting product to network with network cable.
3	Power Interface	For connecting product to power with power cord.

Note: • Printer appearance may differ because of various models and functions, so the schematic diagram is only for your reference.

• To avoid loss of data or printer malfunction, do not touch the USB cable, any wireless network adapter, or the printer in the areas shown in the printing process.

Control Panel

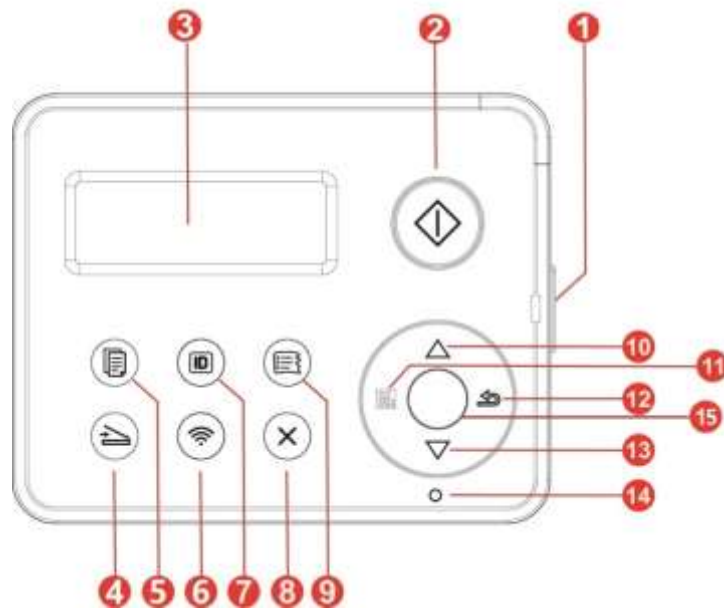

Overview of control panel



No.	Name	Functions
1	Power switch	<ul style="list-style-type: none"> • Turn the power on or off and press this button under Ready state to enter energy-saving mode. • Press and hold this button for more than 2s to turn the printer power off.
2	Start Button	<ul style="list-style-type: none"> • This is used to start relevant operations after finishing operation settings. • In case of a feed failure, please press this key for pick-up and printing again.
3	LCD Display	<ul style="list-style-type: none"> • Display operation interface and product information.
4	Scan Button	<ul style="list-style-type: none"> • Press this button to enter into scan mode.
5	Copy Button	<ul style="list-style-type: none"> • Press this button to enter into copy mode.
6	Wi-Fi button	<ul style="list-style-type: none"> • Short press Wi-Fi button to turn on direct Wi-Fi connection of the printer and automatically print out "Mobile Device Wi-Fi Connection Wizard" page (for models with Wi-Fi function only). • Long press Wi-Fi button for over 2s to start WPS when Wi-Fi is not connected or to disconnect Wi-Fi when it has already been connected (for models with Wi-Fi function only). • Open save toner function (applicable to non-Wi-Fi model only).
7	ID copy	<ul style="list-style-type: none"> • Press it to enter the ID copy mode.
8	Cancel	<ul style="list-style-type: none"> • Execute cancel operation. • Idle state interface under copy mode, to reset the "Number of Copies" to 01.
9	Bill Copy Button	<ul style="list-style-type: none"> • Press this button to enter into Bill Copy mode.

10	UP	<ul style="list-style-type: none"> • Scroll through the menus and options. • Increase 1 copy on the ready interface of Copy mode.
11	Menu	<ul style="list-style-type: none"> • Open the main menu of control panel
12	Back	<ul style="list-style-type: none"> • Return to the previous menu.
13	Down	<ul style="list-style-type: none"> • Scroll through the menus and options. • Decrease 1 copy on the ready interface of Copy mode.
14	Status Light	<ul style="list-style-type: none"> • Indicate the status of printer.
15	OK	<ul style="list-style-type: none"> • Confirm the selection on screen.

Function of power indicator

No.	Status displayed by power indicator	Status	Status Description
1		Die out	The printer is powered off.
2		Always on	Printer is not in sleep state (printer ready, printing, processing, etc).
3		Blink	The printer is in sleep state.

02 Paper and Print Media

Paper Specification

Standard feed tray	Media Type	Plain paper1(70~89g/m ²), Plain paper2(90~105g/m ²),thin paper(60~69g/m ²)
	Media size	A4,A5,A5L,A6,Legal,Letter,JIS-B5,ISO B5, Executive, Folio,Oficio,Statement,16K,32K,Big 16K,Big 32K,B6,Customize paper
	Media weight	60~105 g/m ²
	Maximum capacity of the tray	250 pages(80 g/m ²)
Multipurpose feed tray	Media Type	Plain paper1(70~89g/m ²), Plain paper2(90~105g/m ²),thin paper(60~69g/m ²),thick paper1(106~130g/m ²), thick paper2(130~176g/m ²), thick paper3(177~200g/m ²), Label paper (smooth surface), label paper(matte),carton paper,label paper, envelope
	Media size	A4,A5,A5L,A6, Legal,Letter,JIS-B5,ISO B5,Executive,Folio,Oficio,Statement,16K,32K,Big 16K,Big 32K,No.10 Env,Monarch Env,DL Env,C5 Env,C6 Env, ZL,Janpanese Postcard,Yougata4,Younaga3,Nagagata3,Yougata2,Postcard,B6,C customize paper
	Media weight	60~200 g/m ²
	Maximum capacity of the tray	1 pages

Note: • 80 g/m² standard paper is recommended for this printer.

•It is not recommended to use special paper extensively, which may affect the service life of the printer.

•The print media that does not meet the guidelines listed in this User Guide may result in poor print quality, increased paper jam and excessive wear of the printer.

•Properties such as weight, composition, texture and humidity are important factors affecting the printer performance and output quality.

Special Paper

This printer supports using the special paper for printing. Special paper includes: label paper, envelope, transparent film, thick paper, carton paper, thin paper.

Note: • When using special paper or print media, be sure to select matched print type and size in the print settings so as to get the best print effect.

Please observe the following standards:

Types of Print Media	Correct Practices	Incorrect Practices
Label Paper	<p>Use labels with no exposed lining paper only.</p> <p>Labels shall be put flat when using.</p> <p>Use labels of full sheet only.</p> <p>There is no guarantee that all the labels in the market can meet corresponding requirements.</p>	<p>Use wrinkled, blistered or damaged label papers.</p>
Envelope	<p>Envelopes should be loaded evenly.</p> <p>Use only unsealed envelope paper.</p>	<p>Use wrinkled, nicked, stuck or damaged envelopes.</p> <p>Use envelopes with clips, snaps, windows, or coated linings.</p> <p>Use envelopes with self-adhesive stickers or other synthetic materials.</p>
Transparent Film	<p>Only use transparent films approved for use in laser printers.</p>	<p>Use transparent print media that is not suitable for laser printers.</p>
Thick Paper, carton paper	<p>Only use heavy paper that is approved for use in laser printers and meets the weight specifications of this printer.</p>	<p>Use the paper whose weight is more than the specification of the media recommended for this printer, unless the paper is approved for use in this printer.</p>

Einlegen von Papier

Note: • Druckeraussehen konnte unterschiedlich wegen seine Modelle sein. Die schematische Darstellung ist nur zum Informationszwecken.

Load in the standard feed tray



:To avoid the risk of electrical shock, if you are accessing the controller board or installing optional hardware or memory devices after setting up the printer, turn the printer off, and unplug the power cord from the electrical outlet before continuing. |



:To reduce the risk of equipment instability, load each tray separately. Keep all other trays closed until needed.

1. Remove the standard feed tray from the printer completely.

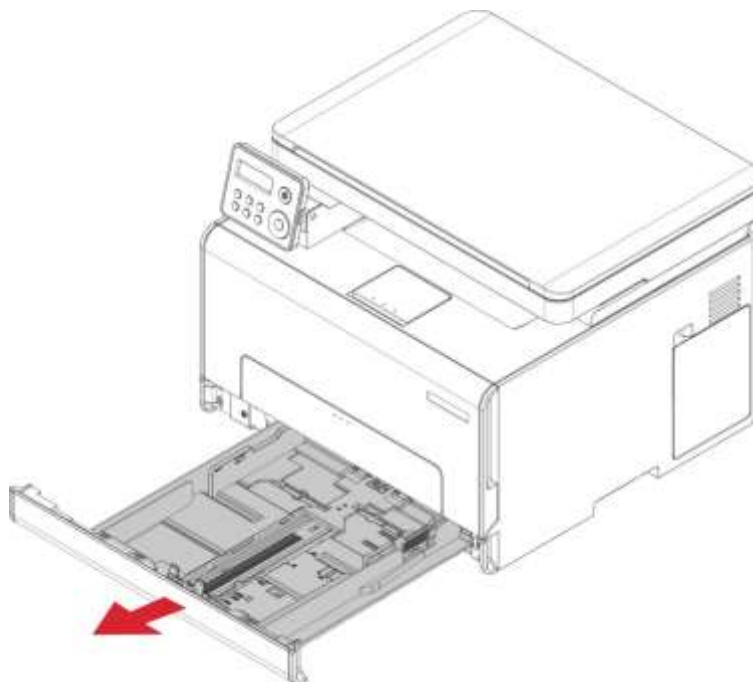

Note: • To avoid paper jams, do not remove the tray while the printer is busy.

2. Flex, fan out and align the paper edges before loading.

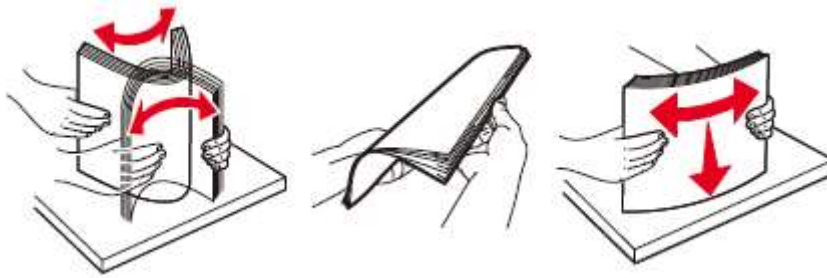

3. Load the paper with the printable side facing up.

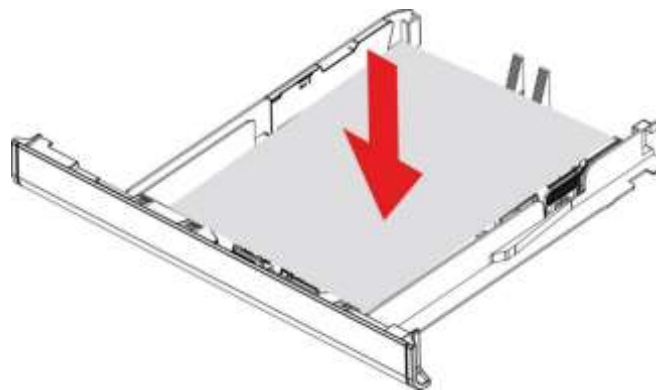

Note: • For single-sided printing, load the paper with the printing side facing up and the header facing the inside of the tray.

• To not slide paper into the tray.

• To avoid paper jams, make sure that the stack height is below the maximum paper fill indicator.

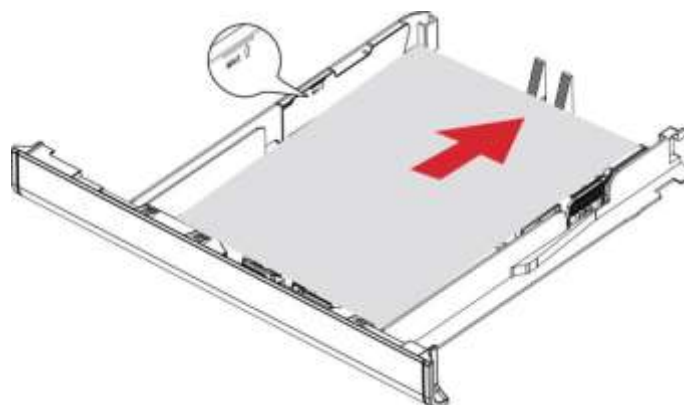

4. Adjust the guide to match the size of the loaded paper.

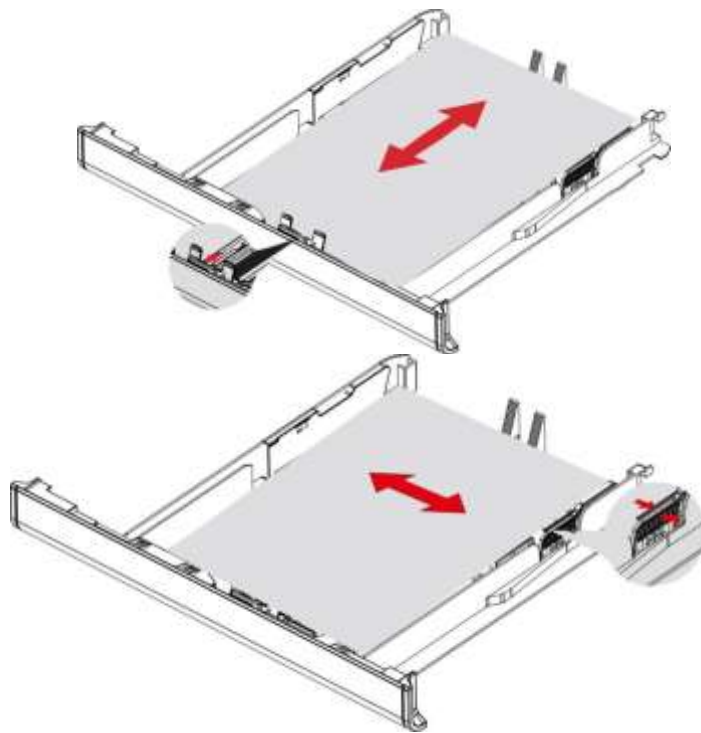

5. Insert the tray.

Install the multipurpose feed tray

1. Adjust the guide to match the size of the loaded paper.

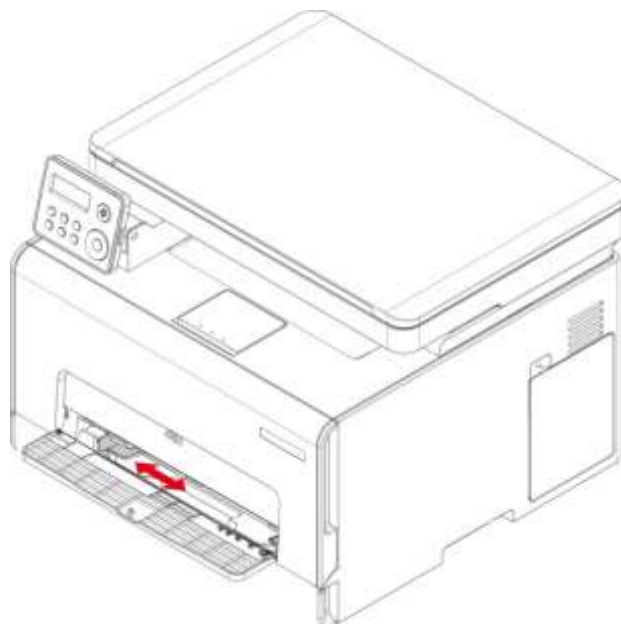

2. Load a sheet of paper with the printable side facing up.

Note: • For single-sided printing, load the paper with the printable side facing up and the top edge going into the printer first.

• For better printing effect, it is recommended to use new, undamaged paper.

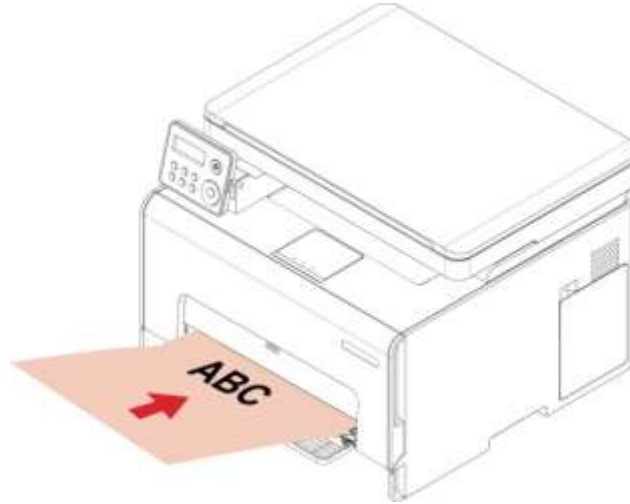

3. Feed the paper until its front edge is pulled in.

Note: • To avoid paper jams, do not force paper into the manual tray.

Paper and Manuscript Use Process

Manuscript requirements:

Source	Type	Size
Platen	--	A4,A5,A6,B5,Letter, Full Platen, Custom

03 Driver installation and uninstallation

Driver Setup

This software provides a one-click installation method for driver installation on Windows and macOS systems, which can help you automatically complete the driver installation faster and more easily.

Note: • Driver installation interface may differ because of different models and functions, so the schematic diagram is only for your reference.

One-click Installation (For Windows and macOS)

One-click installation provides you with three installation methods: "Wi-Fi", "USB", and "Wired Network". This manual focuses on the "Printer Installation by Wi-Fi Connection".

Connect printer via Wi-Fi

Configure Wi-Fi and install driver via USB cable

1. Computer is already connected to router via Wi-Fi.

Note: • Printers only support 2.4 GHz network when it is configured with Wi-Fi network.

• You can print "Network configuration page" to confirm printer network connection status to see if printer is connected with network.

2. Connect the printer to computer via USB cable, then power the printer on.

3. Insert the accompanying installation disk into the computer CD drive, or log in to Pantum official website (www.pantum.com) to download the drive.

4. Read and agree to the terms contained in the End User License Agreement and the Privacy Policy, click the "Next" button in the lower right corner of the interface to enter the driver installation interface.

5. Click on "One-click installation" button under Wi-Fi to install the driver.

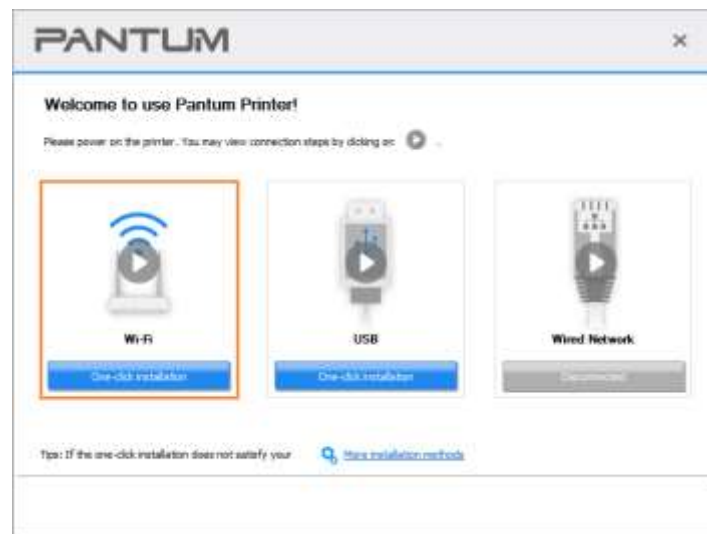

6. After the installation, click "Print & Test Page" button. If your printer prints the test page successfully, it means that you have installed the driver correctly. (If you need to install the OCR software under the Windows system, please install it when the computer is connected to the Internet.)

Note: • You can put your mouse cursor in the "One-click installation" button to check the popup information in order to confirm if the current printer is the one you need to install through IP address before you click the button.

Uninstall Driver

Method to uninstall driver under Windows

Windows 7 is taken as the example in the following operation. The information on your computer screen may differ because of multiple operating systems.

1. Click the Start menu of computer and then click All programs.
2. Click Pantum, and then Click Pantum XXX Series.
Pantum XXX Series where XXX represents product model.
3. Click uninstall to delete the driver according to instructions on uninstall window.
4. Restart computer after finishing unloading.

Method to uninstall driver under macOS

macOS10.14 is taken as the example in the following operation. The information on your computer screen may differ because of multiple operating systems.

1. Click "Go" - "Applications" - "Pantum" - "Utilities" - "Pantum Un-install Tool".
2. Delete the driver as instructed in the pop-up Uninstall window.
3. Uninstall complete.

04 Wired network setup (applicable to wired network models)

In case printers support wired network printing, they can be connected to network to control printer to print in wired network mode.

Set IP Address

The IP address of the printer may be automatically obtained through DHCP function or set manually.

Automatic Setting

DHCP automatic setting function is enabled by default on the printer.

1. Connect the printer to the network through a network cable and complete the startup preparation work.
2. The printer will receive the IP address assigned by server automatically. It may take server minutes to receive IP address under the influence of network environment.
You can check the IP address of printer by printing "Network setup page" out, or check network information by viewing the control panel of printer. If the IP address is not listed, please check network environment and then try again after waiting for several minutes.

Note: • If DHCP server fails to assign IP address automatically, the printer will get the link-local address assigned by printer automatically: 169.254.xxx.xxx.

Manual Setting

- To set up IP address for printer through the control panel of printer manually.
- To set up IP address for printer through the embedded Web server manually.

05 Wireless network setup (applicable to Wi-Fi models)

Based on the model, the printer model with Wi-Fi print function supports two types of wireless network connection: Wi-Fi Station and Wi-Fi Direct. Usually, only one connection is enabled between the computer and the printer at a time.



Wi-Fi Station: connecting to a wireless device via router

1. Access point (wireless router)
2. Wireless network printer
3. Computer connecting to access point via wireless network
4. Computer connecting to access point via network cable

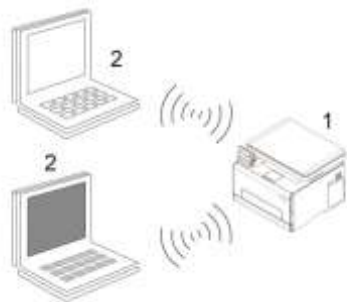

Wi-Fi Direct mode: wireless client is connecting to a printer with Wi-Fi function

1. Wireless network printer
2. Wireless client is directly connecting to a wireless network printer

Basic structure mode

You can connect a computer to your printer via access point (wireless router) as the medium. Access point (wireless router) connection is divided into wireless network setup and Wi-Fi Protected Setup (WPS).

Important: Before wireless network installation, you must learn about the service set identifier (SSID) and password of your access point in order to use them during wireless network setup. If they cannot be determined, please consult your network administrator or a

Wireless network setup tools

If your computer has been installed with a driver and had been connected to wireless network, but the wireless network was changed, you can set it again with wireless network setup tools.

Preliminary preparations

1. Access point (wireless router)
2. A computer that has been connected to network.
3. A printer that has wireless network function.

Setup methods of wireless network setup tools

1. Take the wireless network setup tool in computer.

- 1) Windows system: Click the "Start menu" – "All programs" - "Pantum"— Product name – "Wireless network setup tool".
- 2) macOS system: click "Go" - "Applications" - "Pantum" - "Utilities" - "Wireless Network Configuration Tool" on the computer Finder menu bar.

How to disable the Wi-Fi network connected

Connect the wireless network in infrastructure mode by the steps above. If connected, the Wi-Fi light on the control panel is normally on. Press and hold this button for more than 2s to disconnect from Wi-Fi network (Wi-Fi light will be off).

06 Web server

You can manage printer setup via the embedded Web server.

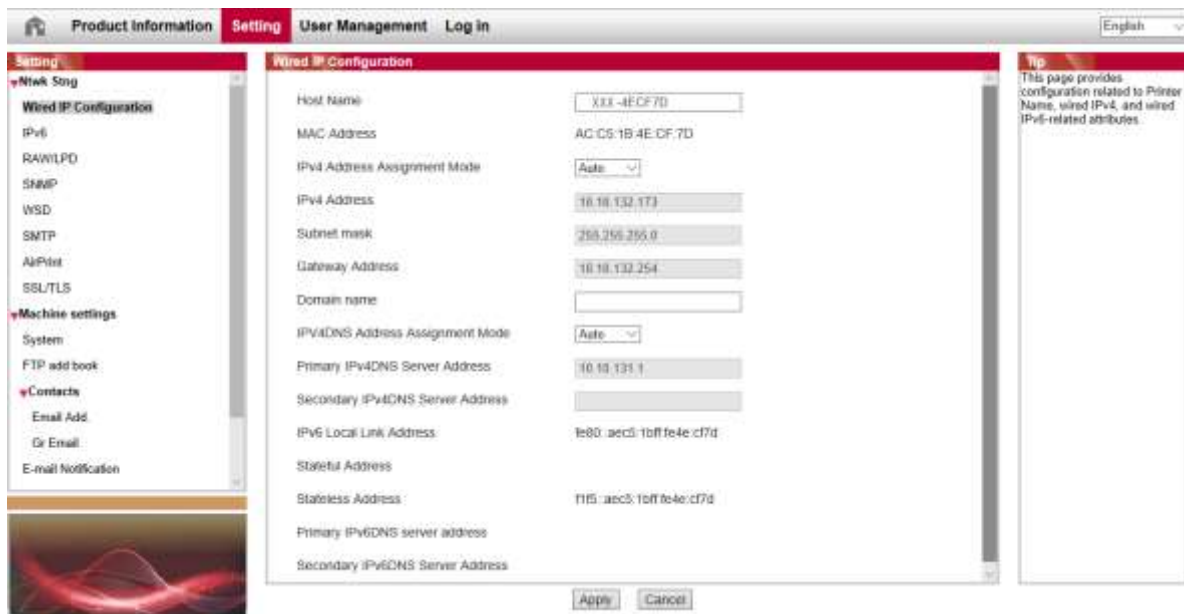

Visit the embedded Web server

1. Turn on the power of printer and computer.
2. Connect the printer to network to ensure that the printer is connected to the network where the computer is connected to.
3. Input the IP address of printer in the address bar of Web browser to visit the Web server imbedded in printer.
4. Click "Log in" option, input user name and password (the default user name is admin and the initial password is 000000) and click "Log in".

Note: • For safety reasons, you are suggested to change the default password, which can be finished in the "User Management" interface.

07 Print

Print Function

You can set the print function through "Start"->"Devices and Printers"- select corresponding printer right click – set print function in "Printing preferences". Some functions are as follows:

Functions	Diagram
Color Printing ¹	
Monocolor printing	
Collate Print	
Reverse Print	
N-in-1	
Poster Print(for Windows Operation System only)	
Zoom Print	
Booklet printing	

Custom Size



Note: • You can realize poster printing feature by selecting 2x2 poster printing in multipage.
• You can enable printing preference and click the help button to view detailed function description.

Duplex

The printer supports duplex printing of plain paper.

Note: • Some paper media are not suitable for duplex printing, and trying duplex printing may result in damage to the printer.
• Duplex is not available for poster printing.
• For information about the paper types and printing media in the feed tray for paper feeding, please refer to [Paper and Print Media](#).

How to carry out auto duplex printing

1. Open the print job to be printed.
2. Select Print from the File menu.
3. Select printer of the corresponding model
4. Click "Printer Properties" to configure the print setting.
5. Select "Duplex Print" under the "Basics" tab, and choose either "Long Edge" or "Short Edge" option.
6. Single click "OK" to finish printing setup. Click "Print" to realize auto duplex printing.

Print without margins

This printer supports borderless printing, so you can set the margins for the printed image by following these steps.

The operation steps are as follows:

The Windows 10 system is taken as an example in the following steps. The information indicated on your computer screen may vary from operating system to operating system.

1. Open the file you want to print. Click the "File" menu in the upper left corner. Select "Print" to bring up the print driver.
2. Select the corresponding printer model.
3. Click "Printer Properties/Preferences" to configure the printing.
4. Enter the "Layout" option interface, check "Printing without Margins", and click "OK".

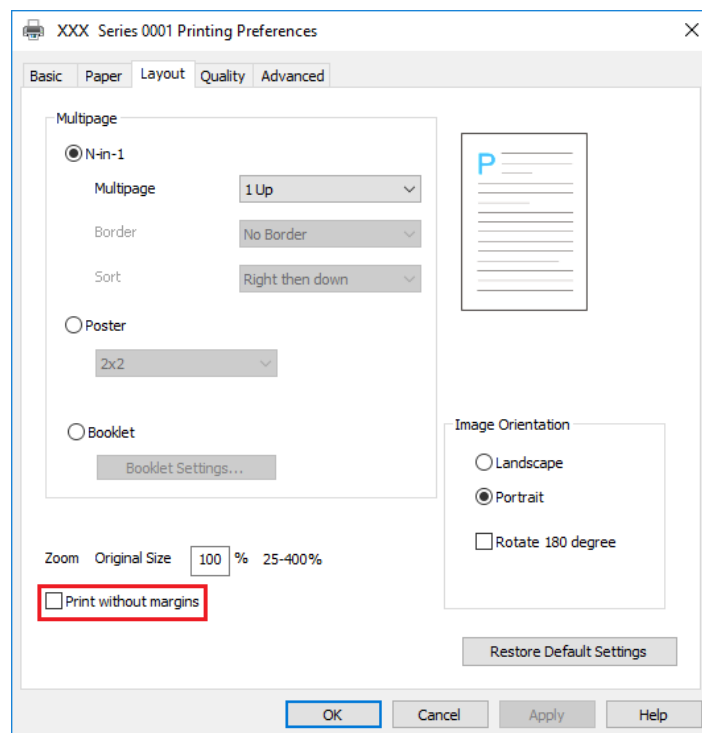

Red Auto Enhancement function

When the red content on the printed portrait does not meet the expectation, you can try to adjust the color of the portrait via the "Red Auto Enhancement" function. The operation steps are as follows:

The Windows 7 system is taken as an example in the following steps. The information indicated on your computer screen may vary from operating system to operating system.

1. Open the file you want to print. Click the "File" menu in the upper left corner. Select "Print" to bring up the print driver.
2. Select the corresponding printer model.
3. Click "Printer Properties/Preferences" to configure the printing.
4. Enter the "Quality" option interface. Check "Red Auto Enhancement" and click "Settings".

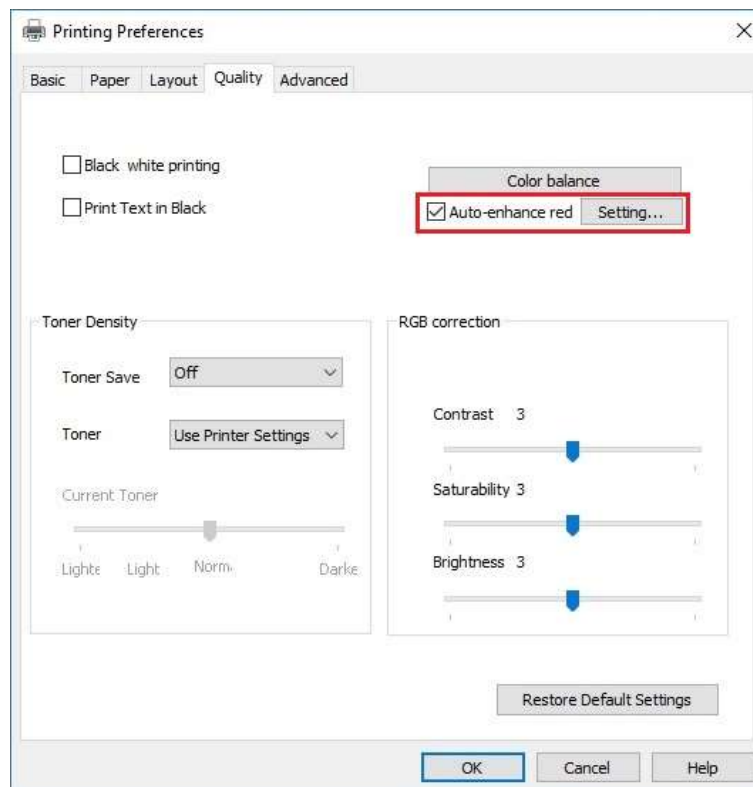

5. In the interface of "Red Enhancement Option Setting", click the "Print A Color Atlas" button to print the color atlas.

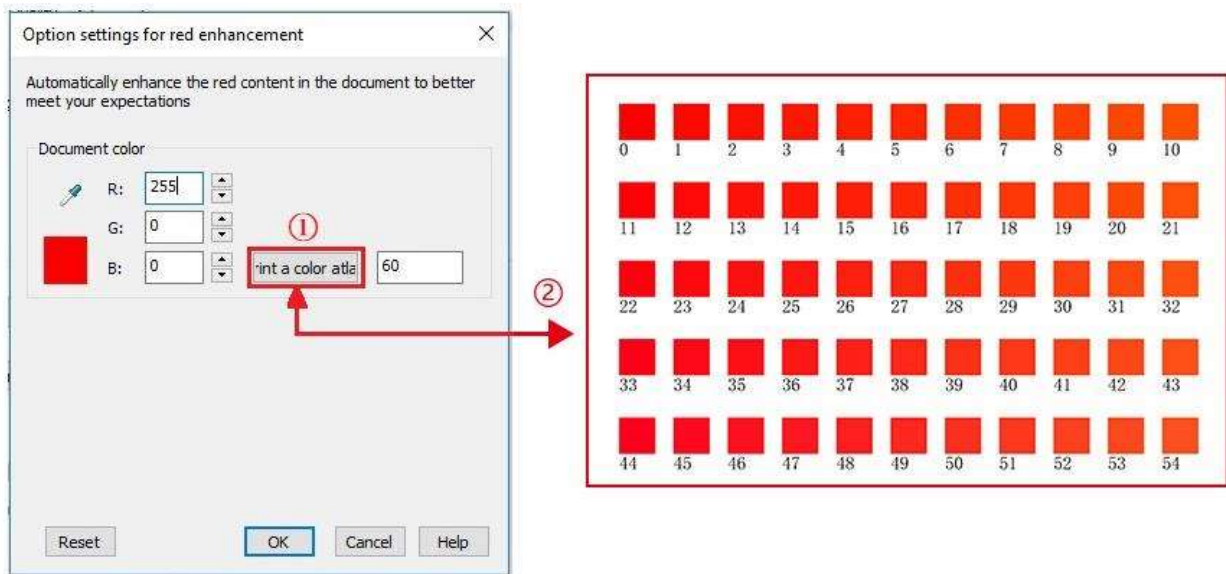

6. Drag " " onto the portrait to be adjusted, and adjust the value of "Print A Color Atlas" as required by referring to the printed color atlas.

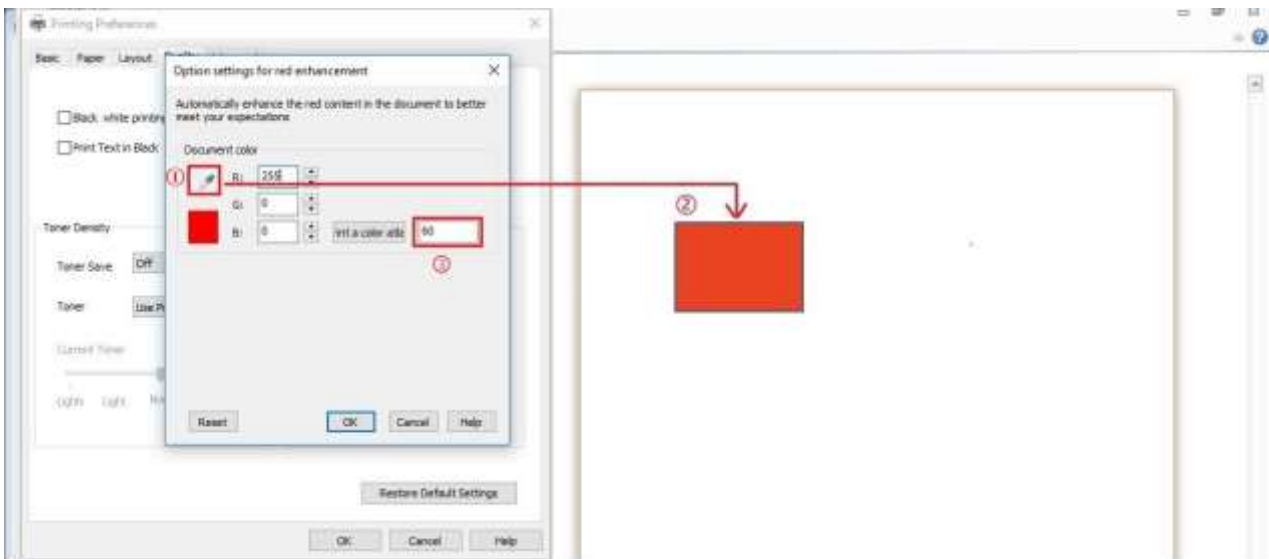

7. Click the "OK"/"Apply" button in the bottom left corner to complete the printing setup. Click "Print" to enable the "Red Auto Enhancement" printing feature.

Note: • Red enhancement printing only works for a single RGB value of the portrait.
• Click the "Print A Color Atlas" button to print a test page of color atlas. The value of color atlas ranges from 0 to 120, and 0 represents pure red.

Set transfer print parameters

If the printed image is mottled or blotchy-looking, you can try to adjust the transfer print parameters through Printer Setup.

The steps are as follows: (Suitable for printers installed via USB connection)

Windows 7 is taken as the example in the following operation. The information on your computer screen may differ because of multiple operating systems.

1. Enter the "Start menu" – "Control Panel" –view "Devices and Printers".
2. Right click printer and select "Printer properties" in the pull-down menu.
3. Enter "Printer Setup" option.
4. Click "Transfer Settings" to adjust the transfer parameters.

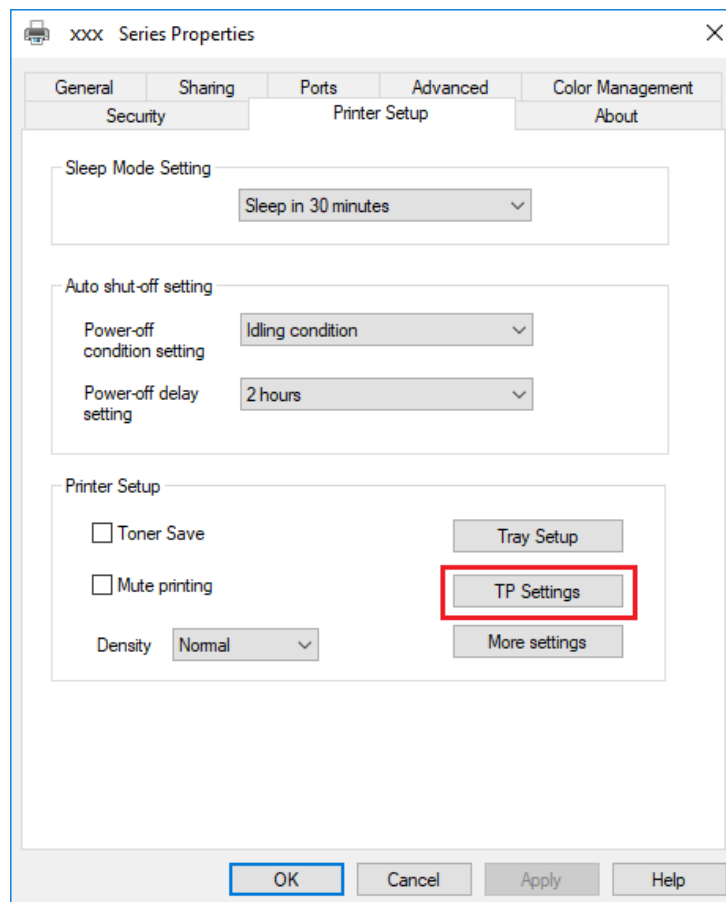

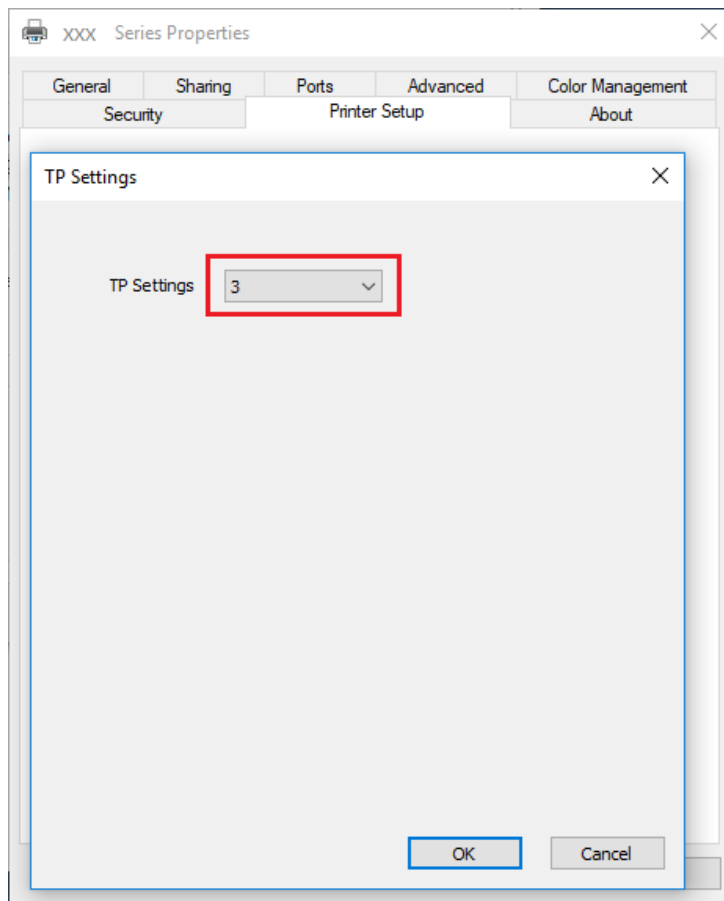

Note: • You can also set transfer print parameters through buttons on control panel.

08 Copying

Copying function

	Copying function	Instructions
Common copying	Color	It is used for color or monochrome copying.
	Copy source	Set the paper size of the originals.
	Copy To	Set the paper size and type of the specified tray.
	Image quality	Set the definition mode to improve the copying effect.
	Intensity	Adjust deep-light copying effect by setting intensity.
	Resizing	Reduce or enlarge the size of image copied.
	Multipage	Print a multi-page document to a piece of paper.
	Clone	Print several identical images to a piece of paper.
	Duplex copying	It supports manual duplex copying for originals.
ID copy	Arrangement mode	Set the Layout for Copying ID Card
	Paper Size	Set the paper size.
	Intensity	Adjust deep-light copying effect by setting intensity.
	Color	It is used for color or monochrome copying.
	Arrangement mode	Set the Layout for Copying ID Card
Receipt copying	Paper Size	Set the paper size.
	Intensity	Adjust deep-light copying effect by setting intensity.
	Color	It is used for color or monochrome copying.

Common copying setting

Change related setting through setting menu for better copy result.

1. Press "Copy" and then "Menu" on control panel to enter the "Menu Setting" interface.
2. Press "OK" to enter the "Copy Setting" interface.
3. Press "direction key" to select option to be set and press "OK key" to set option.

Note: • Luminosity. Once the option is set,, it will remain effective until it is changed.

• Image Quality, Zoom, N-in-1, Clone and Duplex Copy settings. When the copying is finished, switch by pressing the button on the panel, or restart the printer, the settings will restore to default.

Multipage

A 2- or 4-page file can be copied on a piece of paper through N-in-1 setting, and copying with the glass platen is supported.

The multipage includes 3 modes:

(1) Two-in-one:

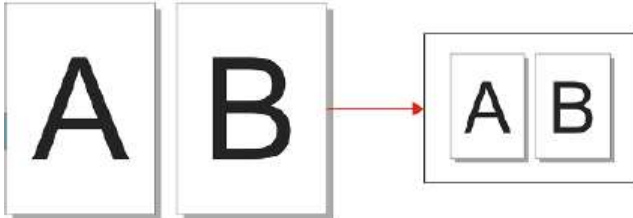

(2) Horizontal four-in-one:



(3) vertical four-in-one:



Note: • "Multipage" and "resizing function" cannot be set at the same time.

Duplex copy

You can use the glass platen for manual duplex copy.
There are 4 modes in total for duplex copying:

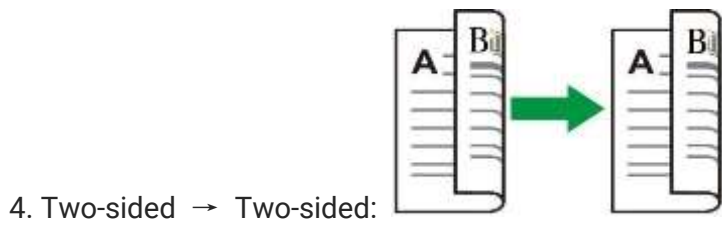
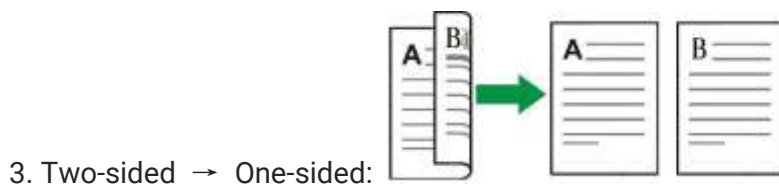
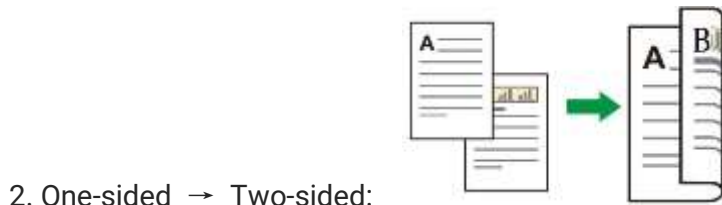
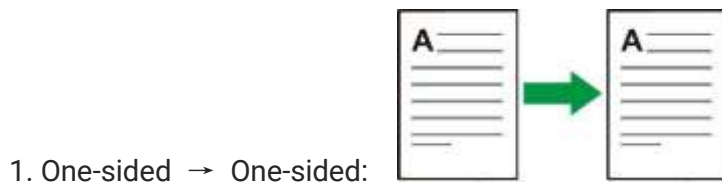

Steps to use Manual Duplex Original Copying

Manual Duplex printing steps are as follows. Take "Duplex→Duplex" mode as example.

1. Put the original into the glass platen with its front side downward, and make sure that there is paper in the tray.

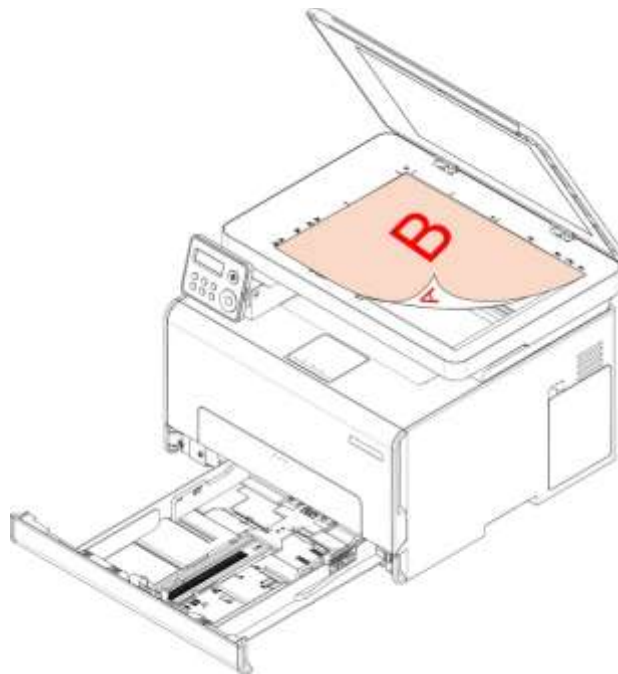

2. Follow the steps described in the [normal copying settings](#). Select the "Duplex -> Duplex" copy mode, press "OK", and save the settings.

3. Press "Start" to begin copying.

4. After copying the first side, open the upper cover of the glass platen, turn the long edge of the original for 180 degrees (with B side down) on the glass platen, and close the upper cover of the glass platen.

Note: • If the turnover prompt on panel times out, the machine will execute one-sided copying automatically.

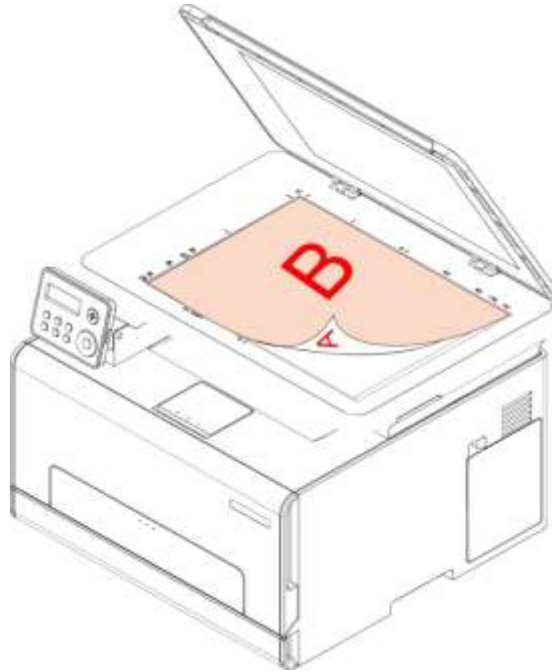

5. Press "Start" to begin copying the other side.

ID copy settings

For better copying effects, you can change the corresponding settings via the "ID Copy Settings" menu.

1. Press "ID Copy" and "Menu" on the control panel to enter the "Menu Settings" interface.
2. Press "OK" button and enter "ID Printing Settings" interface.
3. Press "direction key" to select option to be set and press "OK key" to set option.

Receipt setting

For better copying effect of bills, you can enter the "Bill Copy Setting" menu to change relevant settings.

1. Press "Bill Copy" and then "Menu" on control panel to enter the "Menu Settings" interface.
2. Press "OK" to enter the "Bill Copy Setting" interface.
3. Press "direction key" to select option to be set and press "OK key" to set option.

09 Scan

This printer provides two types of scan: "Push Scan", which means scanning through the printer's Control Panel operations; "Pull Scan" which means scanning through PC terminal scanning the application. Before scanning, please be sure a printer driver has been installed in the computer. This product complies with the TWAIN and Windows Image Application (WIA) standard. If using the application which supports TWAIN and WIA standard, users can use the scan function and directly scan the images to the open application.

Pull Scan

You may scan with the scanning application in PC via USB, wired or wireless connection. Please be sure the printer has been properly connected before scanning.

Windows system scan

Pantum Scan Application

Operation Steps:

1. Double click on "Pantum Scan Application" on the computer.
2. The prompt window is shown as below:

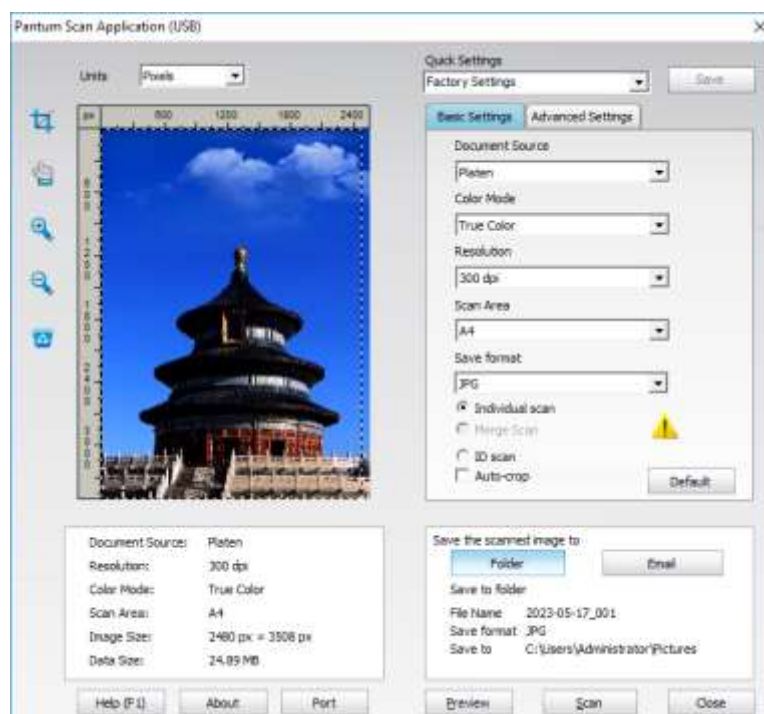

3. Set Scan in the right list. Click "Scan" on the bottom right corner and start scan.

Note: • Images in the format of BMP, JPG, TIF, PDF, PNG, and OFD can be scanned by the Pantum scanning application software. The image text recognition is available for documents in the format of DOCX, XLS, XLSX, PPTX, TXT and searchable PDF. (If you need to use the image text recognition function, please download and install the OCR software according to the interface prompts after the driver installation. For the installation method, please refer to [Driver Setup](#))

•Images in the format of BMP, JPG, TIF, PDF, PNG, and OFD can be scanned by the Pantum scanning application software. The image text recognition is available for documents in the format of DOCX, XLS, XLSX, PPTX, TXT and searchable PDF.

macOS System Scan

ICA Scan

Open ICA via "Print and Scan"

Operation Steps:

1. After installing the printer driver, click "System Preferences" icon on the bottom left corner of the computer desktop.
2. After the window pops up, click on "Print and Scan".
3. After the pop-up window appears, select the desired printer and click the "Scan" button.
4. Click on "Open Scanner" and the scan window will pop up.
5. Click on "Show Details" on the bottom right corner to set the scan parameters.
6. Click on "Scan" on the bottom right corner and start scan.

Call CIA through applications

Operation Steps:

1. Click on "Finder" icon on the bottom left corner of the computer desktop, Find "Image Capture" in "Applications", and click to launch the application.
2. After selecting the printer in the left list, set the scan parameters in the right list. Click on "Scan" on the bottom right corner and start scan.

TWAIN Scan

Take Photoshop as an example. (CS2 and earlier versions are supported)

Operation Steps:

1. Launch Photoshop, click on "File" – "Import" on the top left corner and select TWAIN Scan.
2. After the window pops up, set the scan information in the right list of "Basic Setting" and "Advanced Setting". Click on "Scan" and start scan.

Push Scan

This section introduces how to scan documents into the PC, Email and FTP through the control panel of the printer.

Note: • The document with single scan to PC/Email/FTP can be saved as PDF, TIFF, JPEG or OFD.

Scan to PC

You may operate the printer's control panel to scan a file to PC. (Only support connection method of USB connection line.)

1. Be sure the printer and the computer are both switched on and connected with each other properly.
2. Put the original on the glass platen.
3. Press "Scan" on the control panel to enter the scanning interface.
4. Press "Menu" and then "OK" to enter the "Scan Setting" interface.
5. Press "Menu" and then "OK" to enter the "Scan Setting" interface.
6. Select scanning parameters according to your needs, then press "Start" to start scanning.

Scan to E-mail

You can scan the file as an attachment into the email application. The steps are as follows:

1. Be sure the printer and the computer are both switched on and connected with each other properly.
2. Set up SMTP client.
3. Configure the E-mail address book
4. Put the original on the glass platen.
5. Press "Scan" on the control panel. and then press "OK".
6. Press "Menu" and then "OK" to enter the "Scan Setting" interface.
7. Press "▲" or "▼" to select the options under "Scan to", and then press "OK".
8. Press "▲" or "▼" to select "Scan to E-mail" and press "OK" button.
9. Press "▲" or "▼" to select "E-mail Address Book" or "Group Mail" and press "OK" button.
10. Press "▲" or "▼" to select the address or group. Press "OK" button. Press "Start" to start the scan.

Instructions for settings of group e-mail sending:

Set the group name for group e-mail sending by webpage, and set the members, i.e.the receivers, in the group of group email. After finishing scanning, firmware will send the scanned documents to the mail server. Then mail server sends the documents to every member of the group.

Scan to FTP

Be sure the user is in an Internet-connected environment in scanning files to FTP server. If you want to scan large files, you may need to input the server address, user name and password to log in the server, with specific operation steps as below:

1. Be sure the printer and the computer are both switched on and connected with each other properly.
2. Configure the FTP address book.
3. Put the original on the glass platen.
4. Press "Scan" on the control panel. and then press "OK".
5. Press "▲" or "▼" to select "E-mail Address Book" or "Group Mail" and press "OK" button.
6. Press "▲" or "▼" to select the options under "Scan to", and then press "OK".
7. Press "▲" or "▼" to select "Scan to FTP", and then press "OK".
8. Press "▲" or "▼" to select the server. Press "OK". Press "Start" to start the scan.

10 Routine Maintenance

Note: • Printer appearance may differ because of different models and functions, so the schematic diagram is only for your reference.

Cleaning the Printer



:Some parts of the printer are still in high temperature within a short time after use. To prevent burns, please don't directly touch places labeled with high temperature warning in contact with internal components after opening the printer's front or rear.

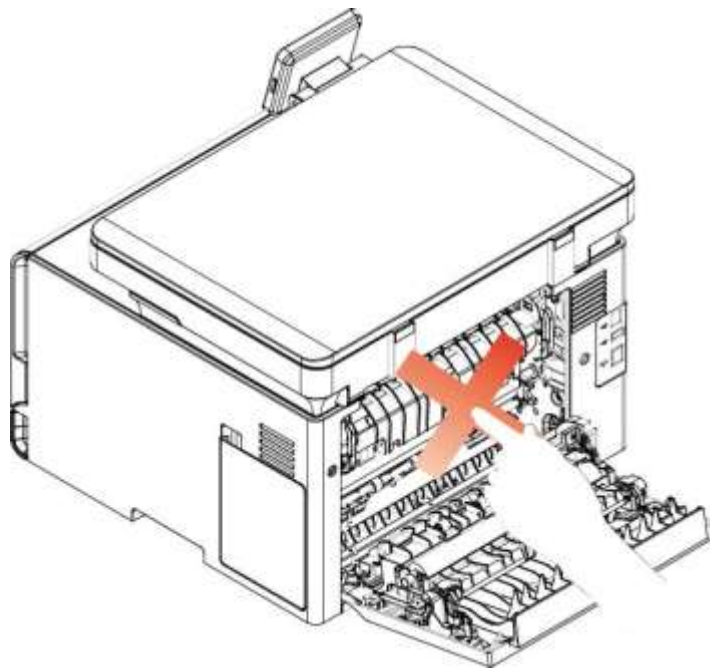

Note: • Disconnect the printer before cleaning.

- Please use mild detergents.

- Use caution when using the printer display to prevent pressing or damaging the touch display.

Please use a soft dry cloth or dip in a neutral detergent or ethanol to clean the display surface. Do not use any organic solvents, acidic or alkaline solutions.

Please use mild detergents



:To avoid the risk of electrical shock when cleaning the exterior of the printer, unplug the power cord from the electrical outlet and disconnect all cables from the printer before proceeding.

Note: • Please perform this job every few months.

- Damage to the printer caused by improper handling is not covered by the printer warranty.

1. Turn off the printer, and then unplug the power cord from the electrical outlet.

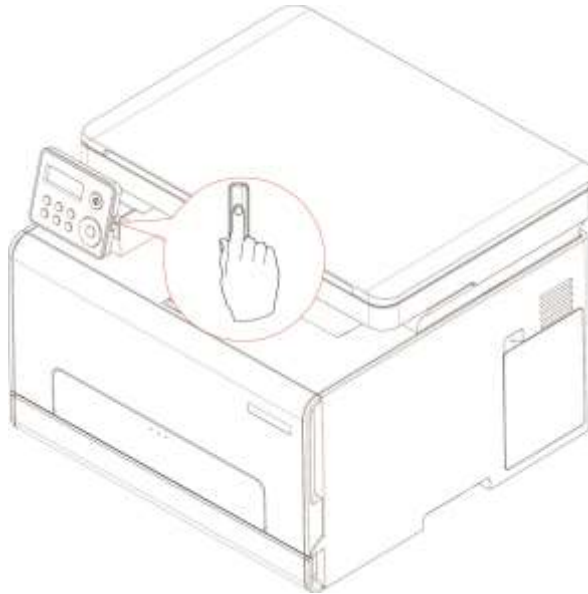

2. Remove the paper from the standard exit and feed tray.

3. Remove any dust, lint, and pieces of paper around the printer using a soft brush or vacuum.

4. Wipe the outside of the printer with a damp, soft, lint-free cloth.

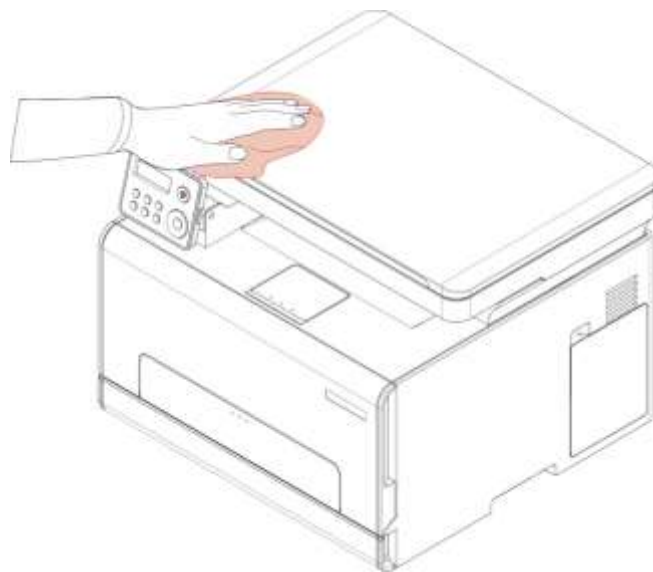

Note: • Do not use household cleaners or detergents, as they may damage the surface of the printer.
• Make sure that all areas of the printer are dry after cleaning.

5. Connect the power cord to the electrical outlet, and then turn on the printer.



:To avoid the risk of fire or electrical shock, connect the power cord to an appropriately rated and properly grounded electrical outlet that is near the product and easily accessible.

Replacing parts and consumables

1. Use and maintenance of toner cartridge.

Please use the original toner cartridge for better printing quality.

Please pay attention to the following items while using the toner cartridge:

- Please keep the toner cartridge in a dry and dark place.
- Do not refill the toner cartridge without permission; otherwise, the damages caused will not be included in the scope of warranty of the printer.
- Please place the toner cartridge in cool and dry places.
- Please do not place the toner cartridge near ignition sources, as the toner inside it is inflammable and may cause fire.
- Please pay attention to toner leakage while it is taking out or disassembled. In case of toner leakage, skin contact with toner or spattering into eyes or mouth, please wash it with clear water immediately, or see a doctor if feeling unwell.
- When placing the cartridge, please stay away from children may contact area.

2. Service life of toner cartridge

- The service life of toner cartridge is depending on the toner quantity needed by printing.
- When a prompt that "The Toner Cartridge life Expired" appears on the display, it indicates its service life expires. So please replace it.

Replacing the toner cartridge

Note: • If the tray is unfolded, remove it before replacing the toner cartridge.

1. Open the front cover, and then push it down hard.

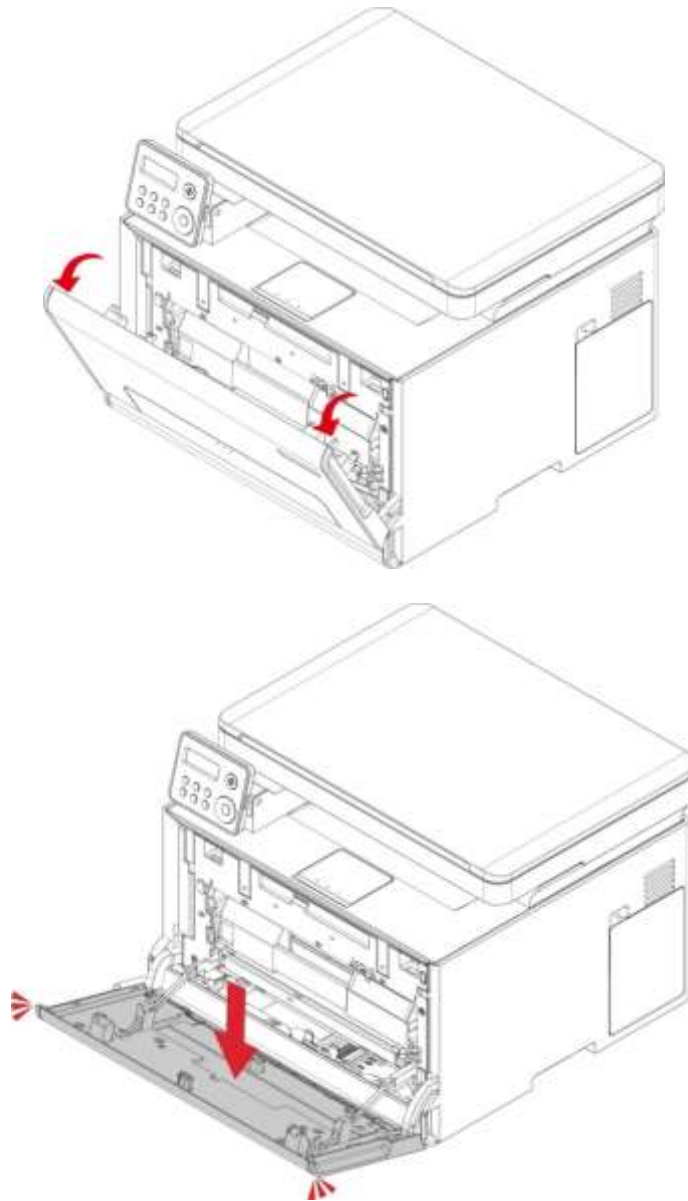

2. Pull out the toner cartridge tray.

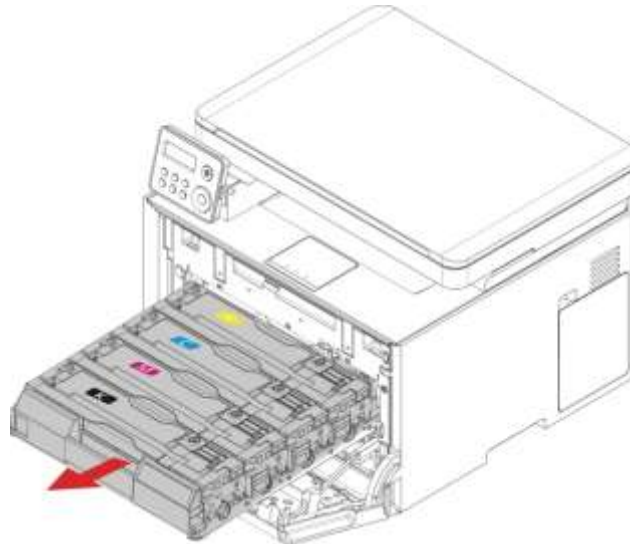

3. Remove the used toner cartridge.

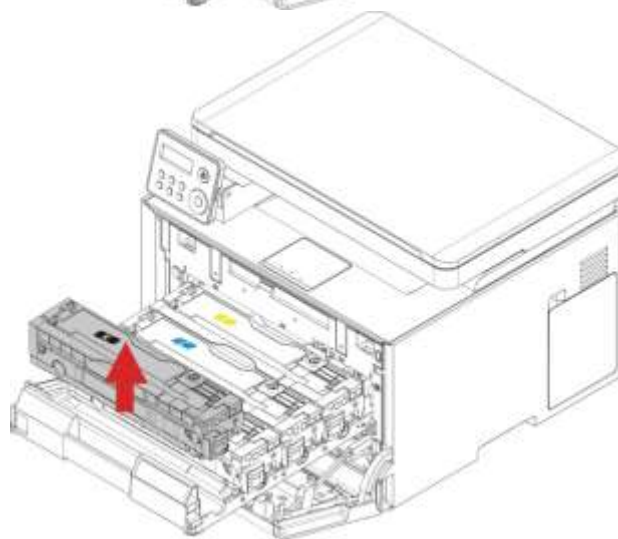
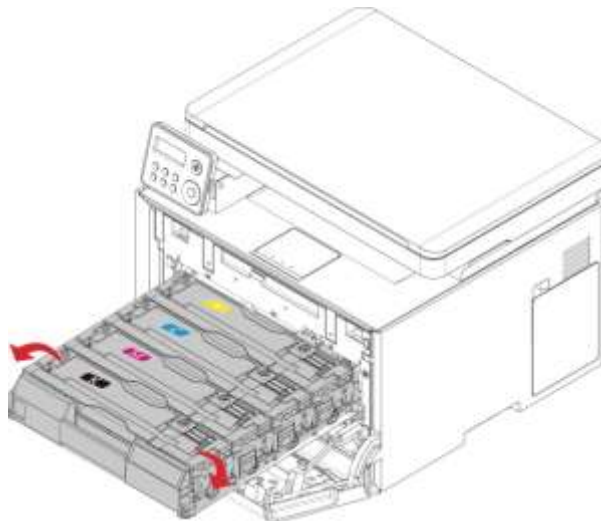

4. Unpack the new toner cartridge.

Note: • Do not expose the bottom of the toner cartridge to direct light. Prolonged exposure to light may cause print quality problems.

• Do not touch the bottom of the toner cartridge. Otherwise it will affect the quality of future print jobs.

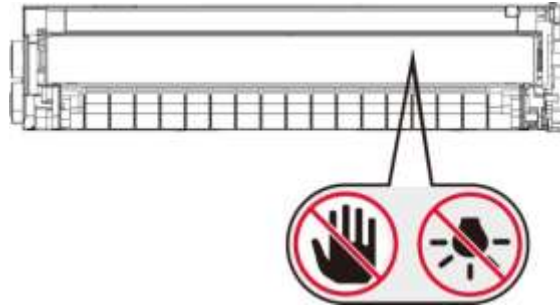

5. Insert a new toner cartridge.

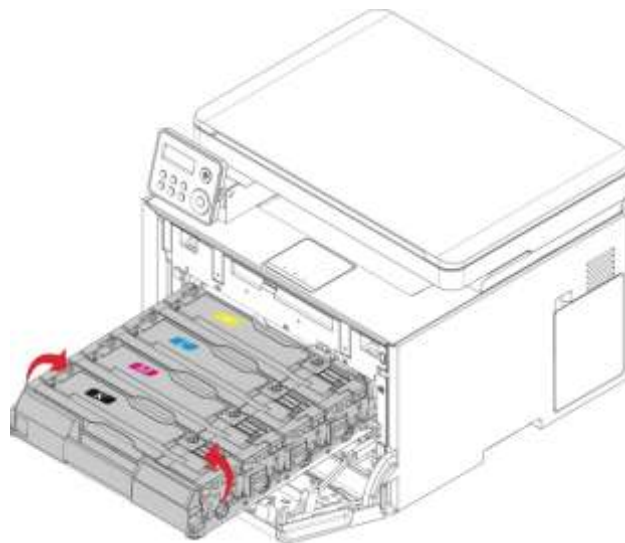
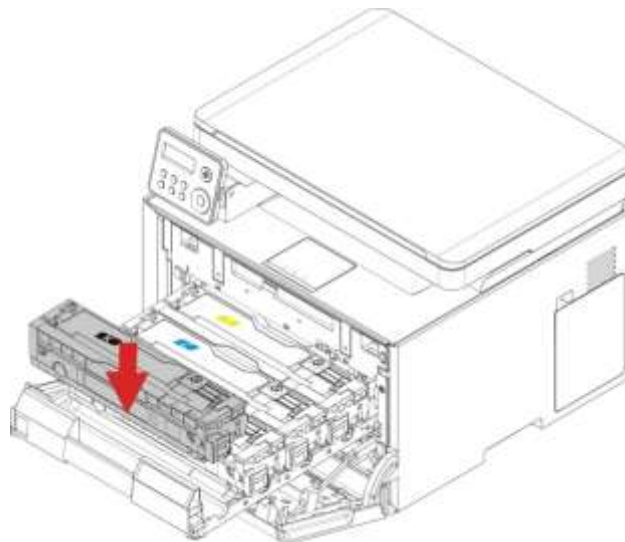

6. Insert the toner cartridge tray, and then close the cover.

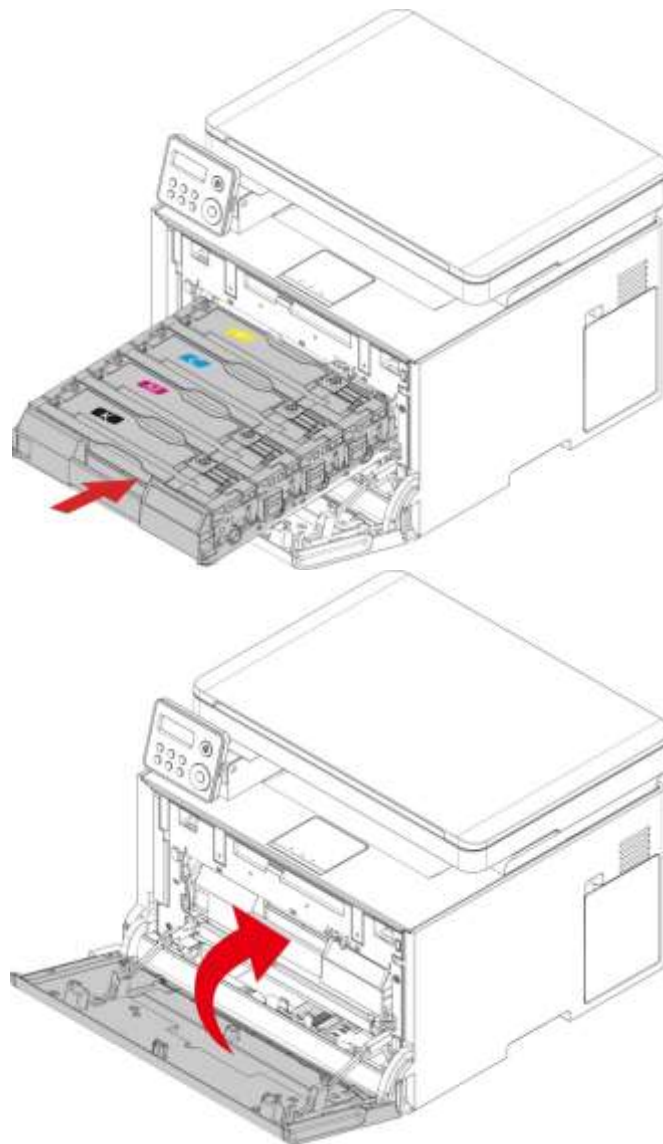

Replacing the waste toner bottle

1. Remove the used waste toner bottle.

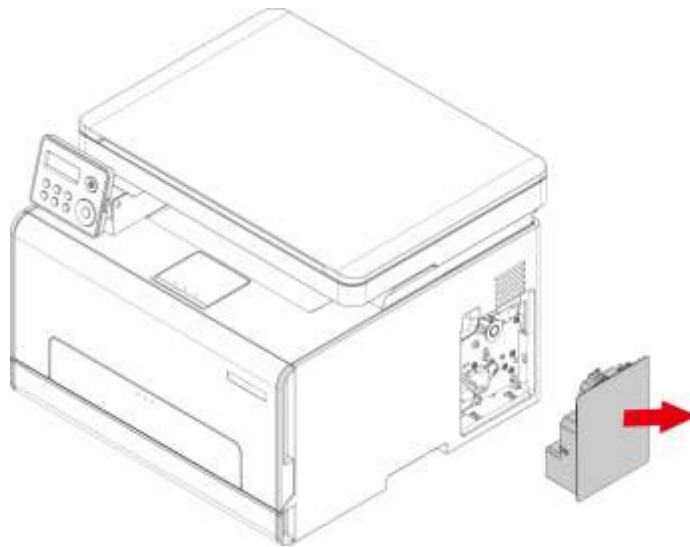

Note: • To avoid toner leakage, keep the waste toner bottle upright.

2. Unpack the new waste toner bottle.
3. Insert a new waste toner bottle.

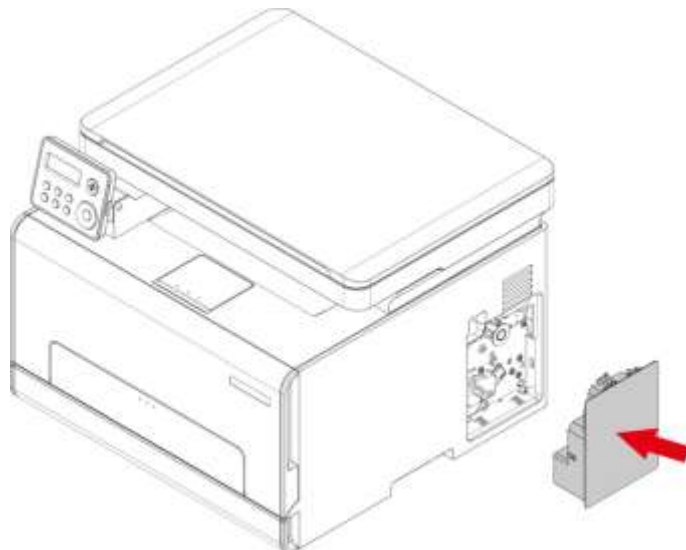

Replace the tray

1. Remove the used tray.

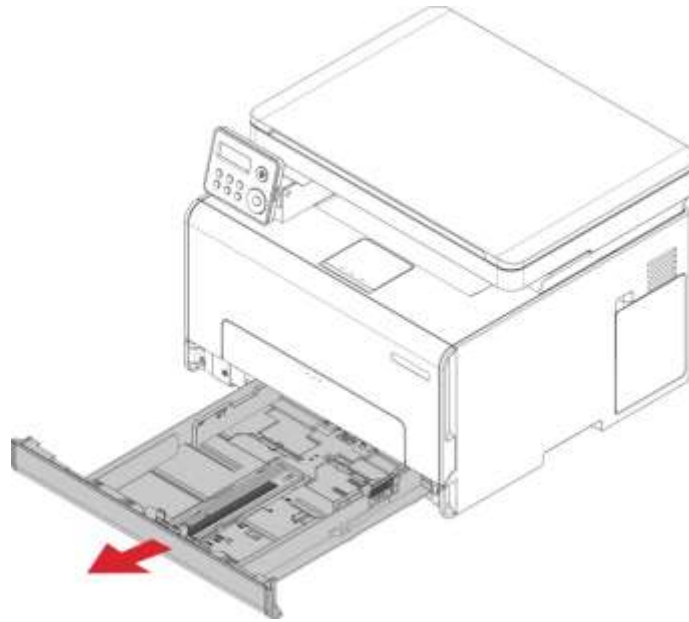

2. Unpack the new tray.

3. Insert a new tray.

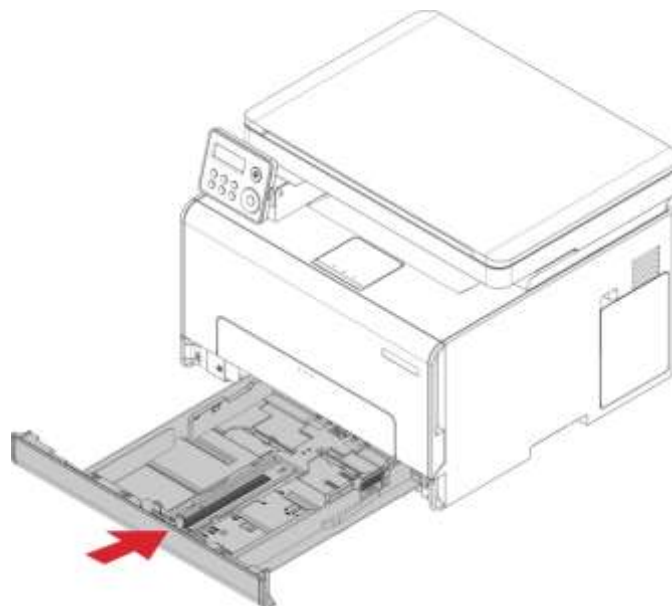

Move the printer

Move the printer to another location



:To avoid the risk of electrical shock, do not place or use this product near water or wet locations.



:If the printer weighs more than 18 kg, then it requires two or more trained personnel to lift it safely.



:To avoid the risk of fire or electrical shock, use only the power cord provided with this product or the manufacturer's authorized replacement.



:When moving the printer, follow these guidelines to avoid personal injury or printer damage:

- Make sure that all covers and trays are closed.
- Turn off the printer, and then unplug the power cord from the electrical outlet.
- Disconnect all cords and cables from the printer.
- If the printer has casters on its base, then carefully move it to the new location. Use caution when passing over thresholds and breaks in flooring.
- Always use the handholds on the printer to lift it.
- Any cart used to move the printer must have a surface able to support the full footprint of the printer.
- Keep the printer upright.
- Avoid violent vibrations when moving.
- Make sure that your fingers are not under the printer when you set it down.
- Make sure that there is adequate clearance around the printer.

Note: • Damage to the printer caused by improper handling is not covered by the printer warranty.

Transporting the printer

When transporting the printer, use the original packaging.

11 Troubleshooting

Please read this section carefully. It may help you to solve common problems encountered during the printing process. If the problems persist, please contact Pantum Aftersales Service Centre.

Prior to handling common problems, first check that:

- The power cord is connected correctly and the printer is powered on.
- All of the protective parts are removed.
- The toner cartridge is installed correctly.
- The paper is correctly loaded into the tray.
- The interface cable between the printer and the computer is connected correctly.
- The correct printer driver has been selected and installed properly.
- The computer port is properly configured and is connected to the correct printer port.

Avoiding jams

Correct loading of paper

Make sure that the paper lies flat in the tray.

Correct loading of paper



Incorrect loading of paper



-
- Do not load or remove a tray while the printer is printing.
 - Do not load too much paper. Make sure that the stack height is below the maximum paper fill indicator.
 - Do not slide paper into the tray. Load paper as shown in the figure.

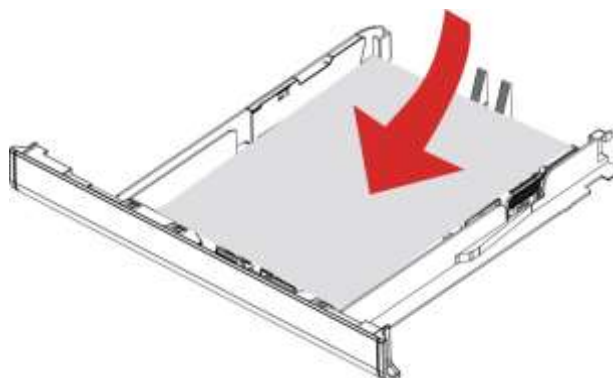

- Make sure that the paper guides are positioned correctly and are not pressing tightly against the paper or envelopes.
- After loading the paper, push the tray into the printer.

Use recommended paper

- Use only recommended paper or special media.
- Do not load paper that is wrinkled, creased, damp, bent, or curled.
- Flex, fan out and align the paper edges before loading.



- Do not use paper that has been cut or trimmed by hand.
- Do not mix paper sizes, weights, or types in the same tray
- Make sure that the paper size and type are set correctly on the computer or printer control panel.
- Store paper according to manufacturer recommendations.

Locate jammed paper

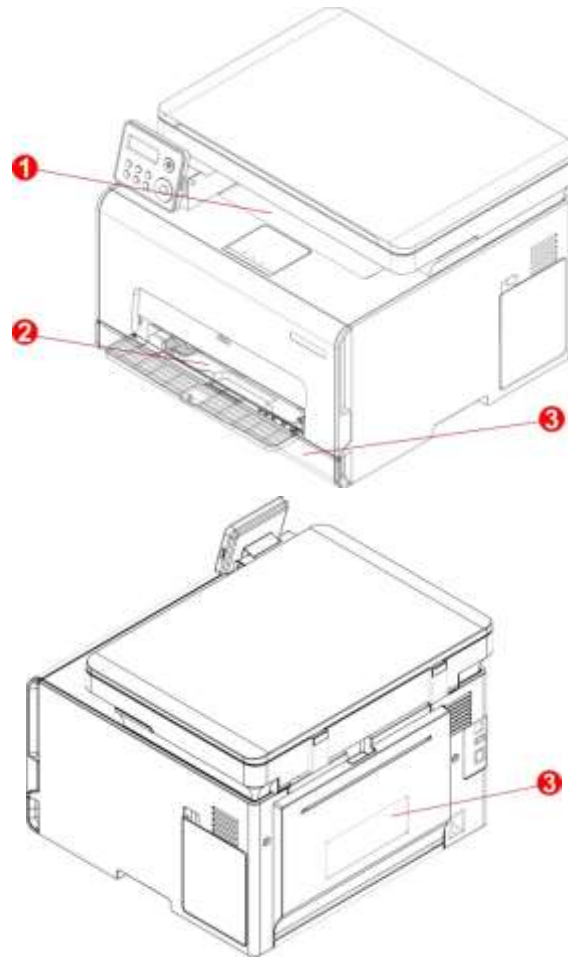

No.	Paper jam locations
1	Standard exit
2	Multipurpose feed tray
3	Standard feed tray
4	Rear cover

Cleaning Jammed Paper

Paper jam in the automatic tray

1. Remove the tray.

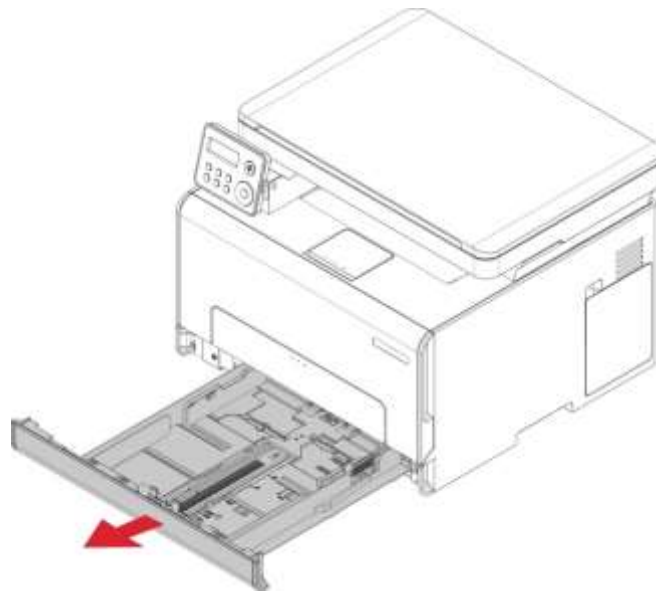

2. Remove the jammed paper.

Note: • Make sure that all paper fragments are removed.

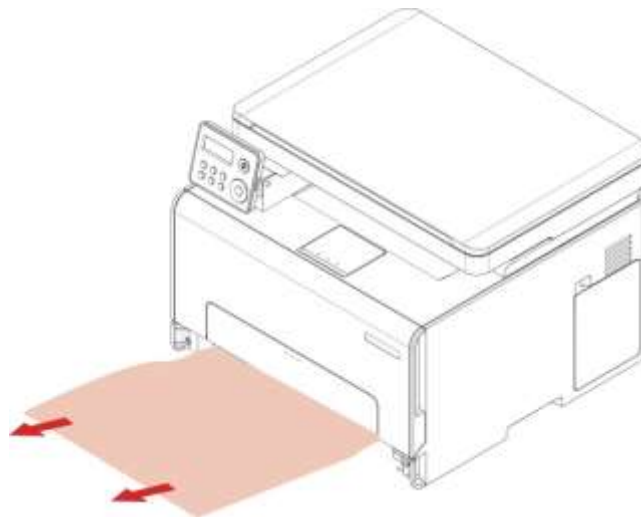

3. Insert the tray.

4. Open the rear cover.



The inside of the printer might be hot. To reduce the risk of injury by a hot component, allow the surface to cool before touching it.

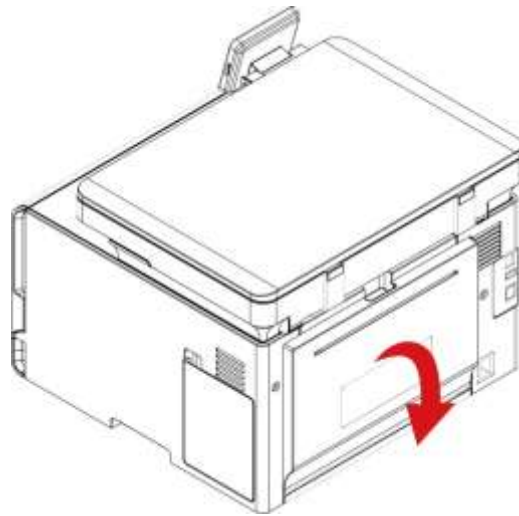

5. Remove the jammed paper.

Note: • Make sure that all paper fragments are removed.

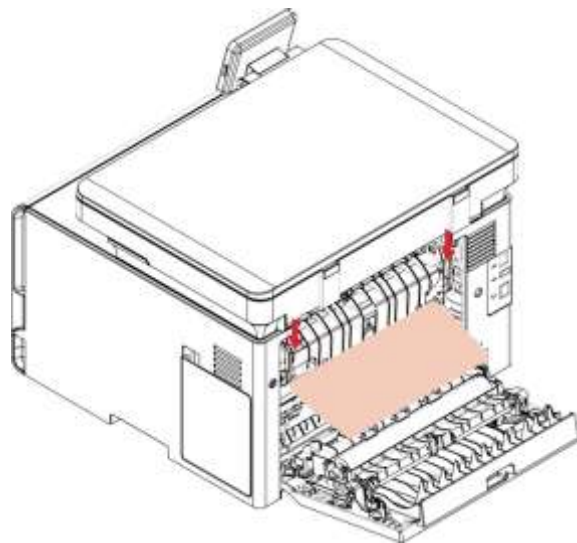

6. Close the cover.

The paper is jammed in the manual feed tray

1. Remove the standard feed tray and press the blue unlock button on the left.

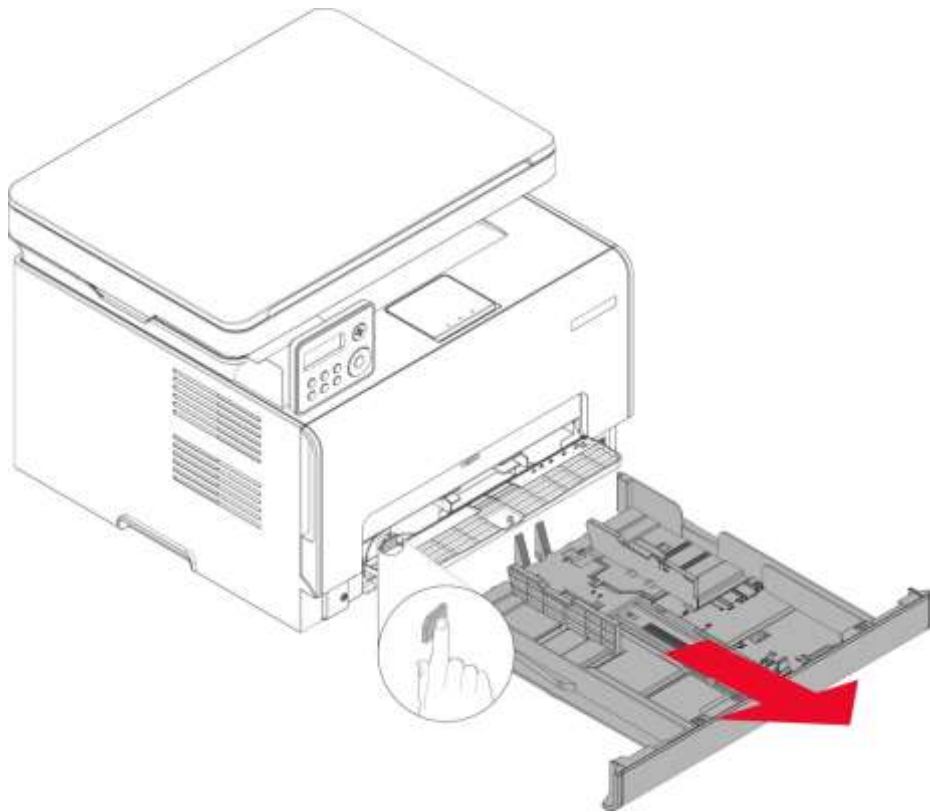

2. Pull out the jammed paper.

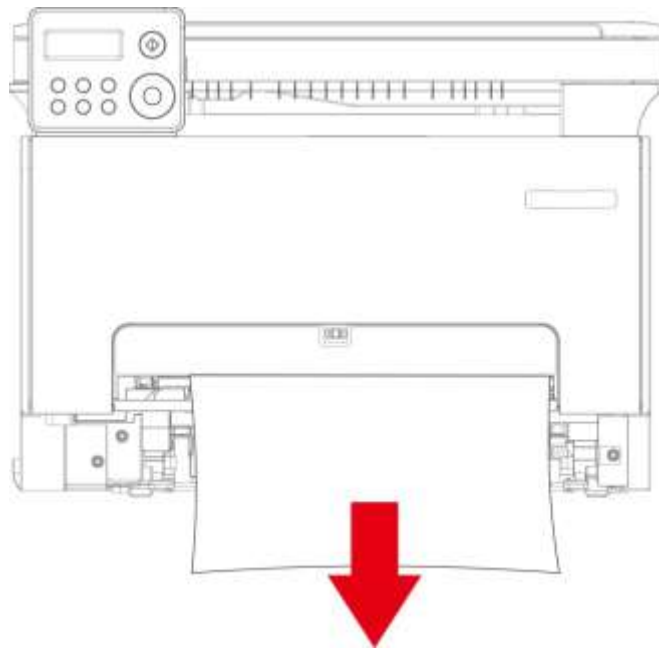

3. Press and push up the metal plate to return it to its original position.

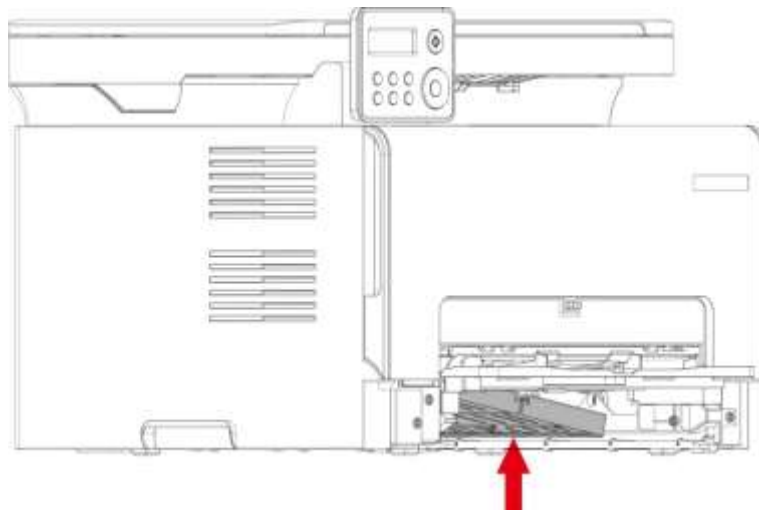

4. Push the standard feed tray in.

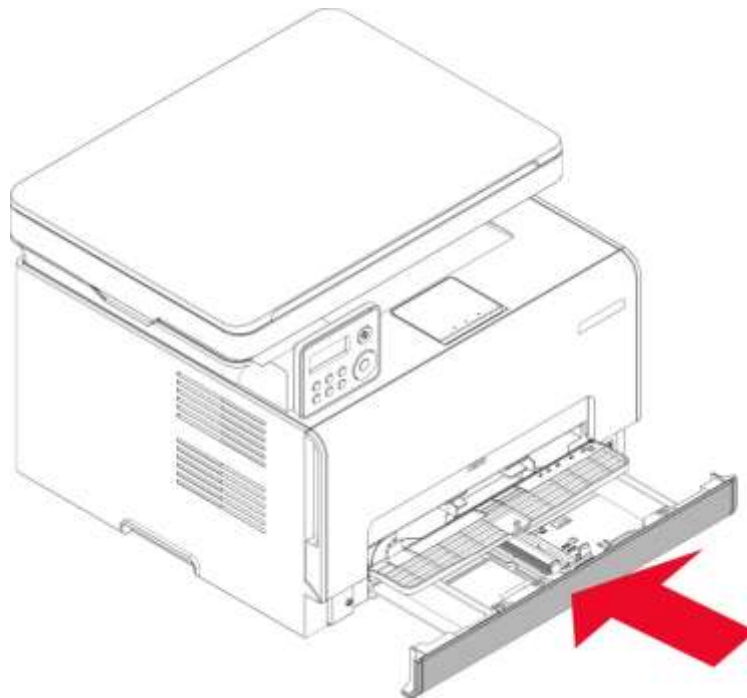

Paper jam in the manual tray

1. Open the front cover, and then push it down hard.

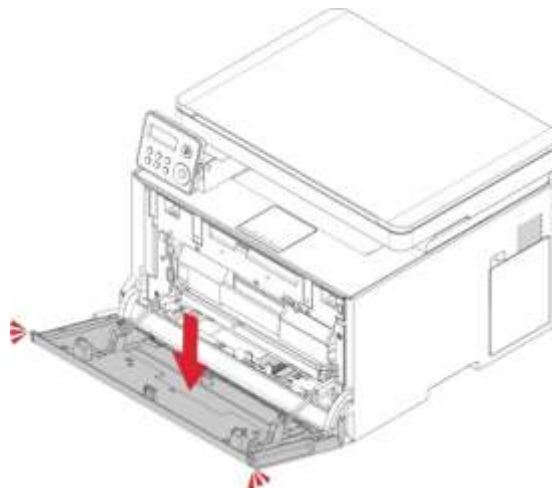
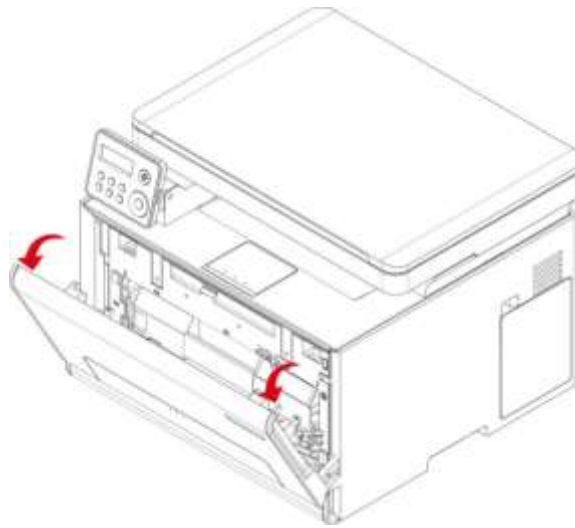

2. Remove the jammed paper.

Note: • Make sure that all paper fragments are removed

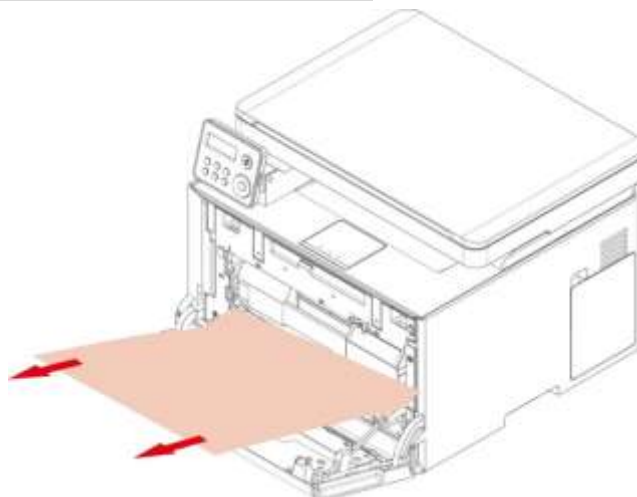

3. Close the front cover.

Paper jam in the rear cover

1. Open the rear cover.



The inside of the printer might be hot. To reduce the risk of injury by a hot component, allow the surface to cool before touching it.

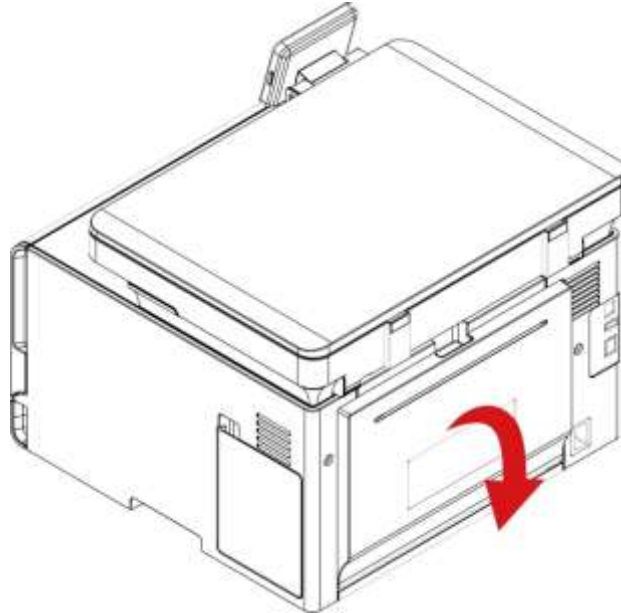

2. Remove the jammed paper.

Note: • Make sure that all paper fragments are removed.

• Fuser area

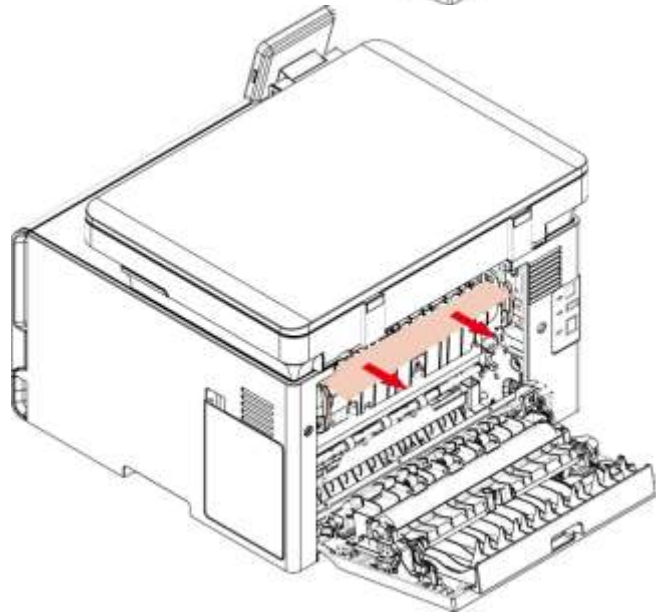
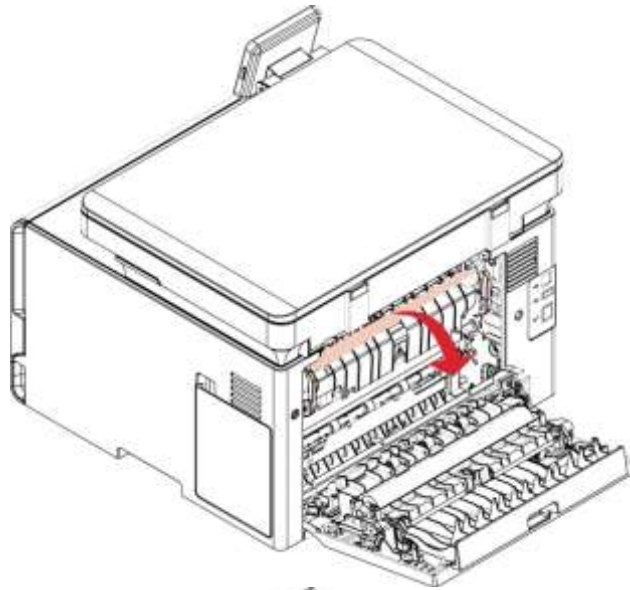

- Below the fuser area

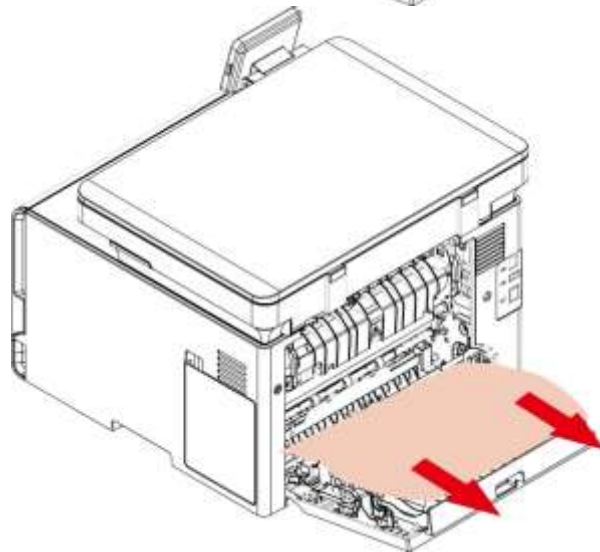
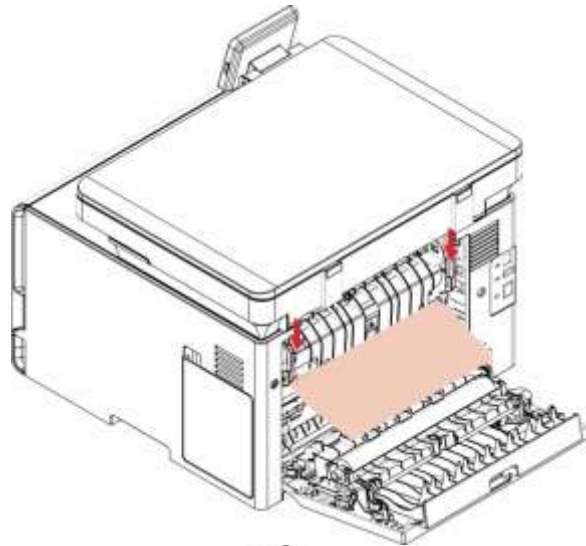

- Duplex unit

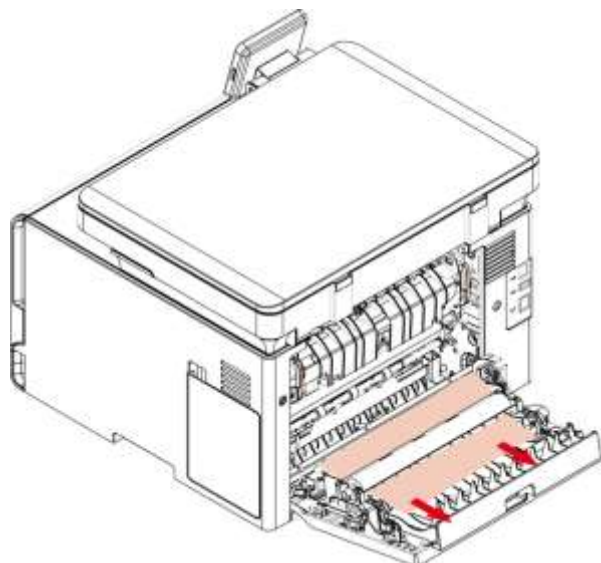

3. Close the cover.

Software Failure

Problem	Solution
The printer icon is not displayed in the "Device and Printer" folder.	Reinstall the printer driver. Ensure that the USB interface cable and the power cord are properly connected.
The printer is in Ready mode but it will not perform any print job.	If the failure still exists after restarting the printer, please reinstall the printer driver. Make sure the network cable of USB cable is connected correctly.
Failed to install the driver	Check whether the print spooler service is enabled. Check the power supply and the connection of the printer. Modify the port IP address of the printer driver.
The driver cannot be used if the IP address of the printer has been changed	If the above method does not work, please reinstall the printer driver. It is recommended that a fixed IP address should be set to the network printer. In the DHCP network, it is recommended to bind the IP address with the MAC address of the printer.

Error Message

Error Message	Cause	Measure
No toner cartridge is installed.	The toner cartridge is not installed correctly or the toner cartridge is damaged.	Install the toner cartridge correctly or replace it with a new one.
Toner Low	Any toner cartridge is running low on toner.	Please prepare a corresponding new toner cartridge.
Cartridge Err	The printer does not support the toner cartridge.	Please replace the toner cartridge supported by the printer.
Toner life end	Toner has been used up.	Replace the toner cartridge.
Feed Failure	Paper is not installed correctly. Paper is beyond the specification.	Please install the paper correctly.
Paper settings mismatched	Paper size or paper type at drive end mismatches setting on printer's control panel.	Please change paper size or paper type at printer end.
Paper jam in printer	Paper is not installed correctly.	Please install the paper correctly.
Waste toner bottle is nearly full	Waste toner bottle works under capacity.	Please prepare a new waste toner bottle.
The waste toner bottle is full.	Waste toner bottle is full.	Please replace the waste toner bottle.
No waste toner bottle is detected.	The waste toner bottle is not installed correctly.	Please remove and reinstall the waste toner bottle.
Scanner is Busy	With other scan jobs.	Please cancel the current scan job or wait for the completion of other scan jobs.
Scan failed	Scanner internal failure.	Please contact Pantum Customer Service.

Note: • If the problem persists, please contact the customer service center. See the Guarantees certificate for contact details.

Common Troubleshooting





Common Problems

Trouble Type	Problem	Cause	Solution
Problems in printing	Poor print quality	See details in Image Defects .	See details in Image Defects .
Problems in copying	Failed to copy	<ul style="list-style-type: none"> • The scanner is damaged. 	<ul style="list-style-type: none"> • Please contact Pantum Customer Service.
	Copy Image Abnormal	<ul style="list-style-type: none"> • The scanner is dirty or defective. • The toner cartridge is dirty or damaged. 	<ul style="list-style-type: none"> • Clean the scanner. • It is suggested to replace the original toner cartridge.
Problems with the Printer	The printer does not work	<ul style="list-style-type: none"> • Power cord of the device is not properly connected. • The cable between the computer and the printer is not connected properly. • Error in specifying the print port. 	<ul style="list-style-type: none"> • Ensure proper connection of the power cord. • Disconnect and then reconnect the printer cable. • Check the Windows printer settings to ensure that the print job has been sent to the correct port. If the computer has more than one port, make sure that the printer is connected to the correct port.
		<ul style="list-style-type: none"> • The printer is offline and User Guide of Printer is checked. • The printer has not recovered from an internal error, such as a paper jam, paper empty, etc. • Driver program of printer is not installed correctly. 	<ul style="list-style-type: none"> • Make sure that the printer is in the normal online status. • Please eliminate errors so that the printer can recover to its normal state. • Unload and reinstall the driver program of printer.
Problems in scanning	Scanning error	<ul style="list-style-type: none"> • Data cable of the device is not properly connected. • The scan driver is installed incorrectly. • The LCD screen prompts error messages. 	<ul style="list-style-type: none"> • Ensure proper connection of the data cable. • Reinstall the scan driver.

Problems with Paper Handling	Paper feed failure	<ul style="list-style-type: none"> • The print media has been loaded incorrectly. • The print media is out of the supported media range. • The feed roller is dirty. • Too many papers in paper tray. 	<ul style="list-style-type: none"> • Please install printing medium correctly; please print with manual feed tray if special printing medium is used to print. • Please use the print media within the specification range. • Clean the feed roller. • Remove excess paper from the tray. For printing on special print media, use the manual tray.
	Paper Jam	<ul style="list-style-type: none"> • Too many papers in paper tray. • The print media is out of the supported media range. • There is foreign matter in the paper path. • The feed roller is dirty. • Internal parts failure. 	<ul style="list-style-type: none"> • Remove excess paper from the tray. For printing on special print media, use the manual tray. • Make sure to use the paper that meets specifications. For printing on special print media, use the manual tray. • Clean the paper path. • Clean the feed roller.
	Print multipage feed	<ul style="list-style-type: none"> • Excessive static electricity on the print media. • The print media is damp and is sticking together. • Internal parts failure. 	<ul style="list-style-type: none"> • Separate the print media to eliminate some static electricity. It is suggested that you use the recommended print media. • Separate the print media or use better quality and dry print media.

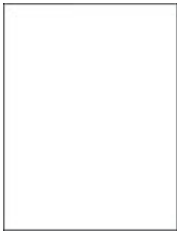
Note: • If the problem persists, please contact the customer service center. See the Guarantees certificate for contact details.

Image Defects

Problem	Cause	Solution
 <p>Blank or white pages</p>	<ul style="list-style-type: none"> • Toner cartridge is not installed properly. 	<ul style="list-style-type: none"> • Pull out the toner cartridge tray, remove the toner cartridge, then insert the toner cartridge, and insert the toner cartridge tray.
 <p>Dark print</p>	<ul style="list-style-type: none"> • A higher density is set when printing. • The print media does not meet the usage specification. For example, the print media is textured, damp, or too rough. • The paper used has been stored in the air for a prolonged time. 	<ul style="list-style-type: none"> • Adjust the toner density from "Printing Preferences" according to your operating system, or by selecting "Print Density" on the control panel. • Please correctly use the medium conforming to the specifications. • Keep the paper in its original wrapper before use. • Make the "Full Calibration" settings.
 <p>Ghost images</p>	<ul style="list-style-type: none"> • The tray fails to load the media properly. • Toner cartridge is not installed properly. 	<ul style="list-style-type: none"> • Please load the paper correctly. See Paper Feeding for how to feed the paper correctly. • Pull out the toner cartridge tray, remove the toner cartridge, then insert the toner cartridge, and insert the toner cartridge tray. • Make "Position Calibration" or "Full Calibration" settings.
 <p>Gray or colored background</p>	<ul style="list-style-type: none"> • Toner cartridge is not installed properly. • The paper path is dirty. • Scanning exposure. • If a gray or colored background appears during copying or scanning, the glass platen may be dirty. 	<ul style="list-style-type: none"> • Pull out the toner cartridge tray, remove the toner cartridge, then insert the toner cartridge, and insert the toner cartridge tray. • Clean the paper path. • Please close the cover on the manuscript, and then carry out copying and scanning. • Clean the platen glass.
 <p>Incorrect margins</p>	<ul style="list-style-type: none"> • The tray fails to load the media properly. • The print margin is set incorrectly. 	<ul style="list-style-type: none"> • Please load the paper correctly. See Paper Feeding for how to feed the paper correctly. • Please set the correct print margin. • Make "Position Calibration" or "Full Calibration" settings.



Light print

- A lower density is set when printing.
- The print media does not meet the usage specification. For example, the print media is textured, damp, or too rough.
- The resolution in the print program is set too low, and the density is set too low.
- The paper used has been stored in the air for a prolonged time.
- Toner cartridge is not installed properly.
- Toner Save set is checked.
- Please correctly use the medium conforming to the specifications.
- Adjust the toner density from "Printing Preferences" according to your operating system, or by selecting "Print Density" on the control panel.
- Keep the paper in its original wrapper before use.
- Pull out the toner cartridge tray, remove the toner cartridge, then insert the toner cartridge, and insert the toner cartridge tray.
- Please check whether the Toner Save mode is enabled.
- Make the "Full Calibration" settings..



Missing color

- Toner cartridge is not installed properly.
- The developing unit of the missing color is not installed properly.
- Pull out the toner cartridge tray, remove the toner cartridge, then insert the toner cartridge, and insert the toner cartridge tray.
- Please remove the developing unit of the missing color and re-insert it.



Mottles and spots

- The toner cartridge is dirty or leaks toner.
- The print media does not meet the usage specification. For example, the print media is textured, damp, or too rough.
- The paper used has been stored in the air for a prolonged time.
- Toner cartridge is not installed properly.
- Incorrect transfer print settings.
- The paper path is dirty.
- If toner spots appear when copying and scanning, the platen glass may be dirty.
- The scanner is dirty or damaged.
- Please contact the customer service center.
- Please correctly use the medium conforming to the specifications.
- Keep the paper in its original wrapper before use.
- Pull out the toner cartridge tray, remove the toner cartridge, then insert the toner cartridge, and insert the toner cartridge tray.
- Readjust the transfer parameters. Please refer to Transfer Parameter Settings for how to adjust them.
- Clean the paper path.
- Clean the platen glass.



Paper crooked

- The tray fails to load the media properly.
- The paper used has been stored in the air for a prolonged time.

- Please load the paper correctly. See [Paper Feeding](#) for how to feed the paper correctly.
- Keep the paper in its original wrapper before use.



Print is crooked or skewed

- The tray fails to load the media properly.
- The print media does not meet the usage specification. For example, the print media is textured, damp, or too rough.
- The paper used has been stored in the air for a prolonged time.
- The paper path is dirty.

- Please load the paper correctly. See [Paper Feeding](#) for how to feed the paper correctly.
- Please correctly use the medium conforming to the specifications.
- Keep the paper in its original wrapper before use.
- Clean the paper path.



Single color or black images

- Toner cartridge is not installed properly.
- If all-black image appear when copying and scanning, maybe it is scanning exposure, and the cover on the manuscript is not properly closed.
- The scanner is damaged.

- Pull out the toner cartridge tray, remove the toner cartridge, then insert the toner cartridge, and insert the toner cartridge tray.
- Please close the cover on the manuscript, and then carry out copying and scanning.
- Please contact Pantum Customer Service.



Text or image cut off

- The tray fails to load the media properly.
- Toner cartridge is not installed properly.
- There are foreign objects inside the printer.

- Please load the paper correctly. See [Paper Feeding](#) for how to feed the paper correctly.
- Pull out the toner cartridge tray, remove the toner cartridge, then insert the toner cartridge, and insert the toner cartridge tray.
- Please contact the customer service center.



Toner comes off easily

- Print media that does not meet the specifications is used. For example, the media weight is not supported by the printer.
- The paper used has been stored in the air for a prolonged time.

- Please correctly use the medium conforming to the specifications.
- Keep the paper in its original wrapper before use.



Uneven print density

- Toner cartridge is not installed properly.

- Pull out the toner cartridge tray, remove the toner cartridge, then insert the toner cartridge, and insert the toner cartridge tray.
- Make the "Full Calibration" settings.



Horizontal dark lines

- The paper used has been stored in the air for a prolonged time.
- Toner cartridge is not installed properly.

- Keep the paper in its original wrapper before use.
- Pull out the toner cartridge tray, remove the toner cartridge, then insert the toner cartridge, and insert the toner cartridge tray.



Vertical dark lines

- The paper used has been stored in the air for a prolonged time.
- Toner cartridge is not installed properly.
- The paper path is dirty.
- If black vertical stripes appear when copying or scanning, the scanner or the platen glass may be dirty.
- Scanner Light bulb has smudges.
- The scanner is damaged.

- Keep the paper in its original wrapper before use.
- Pull out the toner cartridge tray, remove the toner cartridge, then insert the toner cartridge, and insert the toner cartridge tray.
- Clean the paper path.
- Clean the scanner or the platen glass.
- Please contact Pantum Customer Service.



Horizontal white lines

- Toner cartridge is not installed properly.

- Pull out the toner cartridge tray, remove the toner cartridge, then insert the toner cartridge, and insert the toner cartridge tray.



Vertical white lines

- The print media does not meet the usage specification. For example, the print media is textured, damp, or too rough.
- Toner cartridge is not installed properly.

- Please correctly use the medium conforming to the specifications.
- Pull out the toner cartridge tray, remove the toner cartridge, then insert the toner cartridge, and insert the toner cartridge tray.



- The toner cartridge is damaged.

- It is recommended to replace with the original toner cartridge.

- Please contact Pantum Customer Service.

Repetitive defects

Note: • The faults above can be mitigated by cleaning or replacing the cartridge. If the problem persists, please contact the customer service center. See the Three Guarantees certificate for contact details.

12 Product Specifications

Note: • Specification values are slightly different for different models of printers with different functions. These values are based on the initial data. For more information about the latest specification, please visit: www.pantum.com.

Overview of the Specifications

Product Size(W*D*H)	400mm*400mm*298.5mm
Product weight (including cartridge, excluding the package)	18.2kg
Product weight (including cartridge and package)	21.3kg
Print Environment	Optimal Printing Temp Range: 10-35°C Print humidity range:20%RH~80%RH
Power Voltage	110V Model:AC110-127V,50Hz/60Hz,8A 220V Model:AC220-240V,50Hz/60Hz,4A
Noise(SPL)	Standby: ≤30dB(A) Print/scan: ≤54dB(A) Copy: ≤56dB(A) Mute mode: ≤50dB(A)
Enter network standby time	1 minutes
Default automatic shutdown time(for EU only)	4 hours

Power Consumption	Network standby:wireless<8.00W;without wireless<2.00W
	Shutdown: ≤0.50W
	sleep: ≤1.00W
	Standby: ≤50.00W
TEC: conforming to requirements of Chinese energy efficiency rating	
Operating system	Microsoft Windows XP/ Windows 7/ Windows 8.1/ Windows 10/ Windows 11/Windows Server 2012/2016/2019/2022(32/64 Bit)
	macOS10.10/10.11/10.12/10.13/10.14/10.15/11.5/11.6/12.0.1/12.3/12.4/12.5/12.6/13.1
	Linux Ubuntu 16.04(32/64 Bit)/ Ubuntu 18.04/Ubuntu 20.04/Ubuntu 22.04(64 Bit)/ Astra Linux Special Edition V1.6/Redhat 8.0/Debian 10.0/Centos 7/Centos 8.2(32/64 Bit)
	iOS 11.0-16.5
	Android 6.0-13.0
	HarmonyOS 2.0-3.0
Communication interface	USB 2.0(High Speed)
	IEEE802.3 10/100Base-Tx
	IEEE802.11 b/g/n
	Bluetooth:BLE
Frequency Band	BLE: 2400MHz – 2483.5MHz
	Wi-Fi 2.4GHz : 2400MHz – 2483.5MHz
Note:The above frequency bands are common frequency bands, and different markets will restrict the use of certain frequency bands according to the country's regulatory requirements.	
Maximum output power (Declaration for EU Compliance)	BLE: ≤10.00dBm EIRP
	WLAN 2.4GHz : ≤20.00dBm EIRP

Print Specifications

Print Speed	20ppm(A4)/21ppm(Letter)
Print Time of First Page	Black & White: ≤10s Color: ≤15s
Print Language	GDI

Copy Specifications

Copy Speed	20cpm
FCOT	Flatbed <17 s
Other Copy Functions	ID copy, Receipt copy, N-up copy, Clone copy

Scan Specifications

Scan Type	Flatbed
Scanning speed	20ipm
Maximum Scan Size	216×297mm
Scan Mode	Color/Grey/Black & White
Scan Output Function	Scan to E-mail, PC and FTP

PANTUM